

OPERATING AND INSTALLATION MANUAL

ELECTRIC WATER HEATER

TO - 20



Družstevní závody Dražice-strojírna s.r.o.
Dražice 69, 294 71 Benátky nad Jizerou
tel.: +420 / 326 370 911
fax: +420 / 326 370 980
e-mail: export@dzd.cz

 **DRAŽICE**
NIBE GROUP MEMBER

CONTENTS

1	TECHNICAL SPECIFICATION OF PRODUCT	4
1.1	FUNCTION DESCRIPTION	4
1.2	ADVICE FOR CUSTOMERS	4
1.2.1	HOT WATER CONSUMPTION	4
1.2.2	ENERGY SAVING.....	4
1.2.3	EMERGENCY POWER CONSUMPTION	4
1.3	DESIGN AND GENERAL HEATER DIMENSIONS.....	5
2	OPERATION AND FITTING INSTRUCTIONS.....	6
2.1	OPERATING CONDITIONS	6
2.2	WALL MOUNTING.....	6
2.3	PLUMBING FIXTURE.....	7
2.4	ELECTRIC WIRING	9
2.4.1	ELECTRIC INSTALLATION GENERAL INFORMATION.....	9
2.5	FIRST HEATER COMMISSIONING	10
2.6	PUTTING OUT OF SERVICE, DISCHARGE	10
2.7	INSPECTION, MAINTENANCE & CARE FOR THE APPLIANCE	11
2.8	MOST FREQUENT FUNCTION FAILURES AND THEIR CAUSES	12
3	IMPORTANT NOTICES	12
3.1	INSTALLATION REGULATIONS.....	12
3.2	DISPOSAL OF PACKAGING MATERIAL AND FUNCTIONLESS PRODUCT	13
4	PRODUCT ACCESSORIES	13

CAREFULLY READ THIS MANUAL BEFORE INSTALLING THE WATER HEATER!

Dear Customer,

Družstevní závody Dražice - strojírna s.r.o., would like to thank you for your decision to use a product of our brand. With this guide, we will introduce you to the use, construction, maintenance and other information on electrical water heaters.



The product is not intended to be controlled by

- a) people (including children) with reduced physical, sensual or mental capacities, or
- b) people with insufficient knowledge and experiences unless supervised by responsible person, or unless properly instructed by such responsible person.

The manufacturer reserves the right for engineering modification of the product. The product is designed for permanent contact with drinkable water.

It is recommended to use the product in indoor environment with air temperatures from +2 °C to +45 °C and a relative humidity up to 80 %.

Product's reliability and safety is proven by tests implemented by the Engineering Test Institute in Brno.

Made in the Czech Republic.

Meaning of pictograms used in the Manual



Important information for heater users.



Abiding by the recommendations of the manufacturer serves to ensure trouble-free operation and the long service life of the product.



Caution!
Important notice to be observed.

1 TECHNICAL SPECIFICATION OF PRODUCT

1.1 FUNCTION DESCRIPTION

After the heater is connected to electric network, the heating element starts heating water. The element is turned on and off by a thermostat. Thermostat can be set as per your need within the range from 5 °C to 74 °C. We recommend setting service water to max temperature of 60 °C. This temperature ensures the optimal operation of the heater. After reaching the temperature set, the thermostat switches off the electric circuit and thus discontinues water heating. The control light signals if the element is in operation (light is on) or if it is off (the light goes out). In case of longer operation without using the heated volume, the thermostat has to be set to position 5 °C to 12 °C (set the “snowflake” symbol on the thermostat selector) to avoid its freezing.

1.2 ADVICE FOR CUSTOMERS

1.2.1 HOT WATER CONSUMPTION



With its design, the electric accumulation heater TO - 20 is suitable for installations in bathrooms, lavatories, kitchens or near sanitary units of panel flats, and complies with the requirements of Standards, with the IP 44 protection class. Its benefit is that it heats up water by power in an unlimited all-day time range. The time of heating service water to the recommended temperature of 60 °C is about 31 minutes.



Consumption of hot water in households depends on the number of people, amount of sanitary equipment, length, diameter and insulation of piping in the flat, or on individual habits of users. The cheapest option of water heating comes at the time when the electricity rate is reduced.

1.2.2 ENERGY SAVING



Find out in what time intervals your electricity supplier provides reduced tariff and, depending on that information, select relevant volume and power input of the heater so that your hot water consumption covered the needs of your household.

1.2.3 EMERGENCY POWER CONSUMPTION



According to current legislation, the standby consumption is stated in the value of annual consumption of electric energy (kWh), which is measured according to the corresponding load profile and calculated according to the formulas and requirements of EU Regulation No. 812/2013.

1.3 DESIGN AND GENERAL HEATER DIMENSIONS

The heater tank is made of a steel plate and tested by 1.5 multiple of operation pressure value. The inner surface of the tank is provided (except the stainless coil) with anticorrosion protection of enameled glaze.

In the bottom part of the tank there are wells for placing the heating, regulation and safety element of the water heater (heating element with right thread G 5/4", thermostat sensor and thermal fuses). A thermometer is installed in the top part of the heater that transmits information on heating the volume of service water. The heater tank is provided with a highly valuable polyurethane insulation which ensures minimum heat losses.

Electric wiring is placed in the bottom part of the heater, under an easily removable guard of the heater (by loosening two screws on that guard). Temperature of water can be set by a thermostat within the range between 0 °C and 74° C, using the symbols on the thermostat selector button Figure 1. Cold water inflow is indicated with a blue ring, hot water outflow is indicated with a red ring. All steel parts are protected against corrosion with paint and galvanic coating. To ensure anticorrosion protection, the heating element head is provided with an anode rod that dissolves when the heater is in operation and has to be replaced after 3 years of operation (depending on the aggressiveness of water).

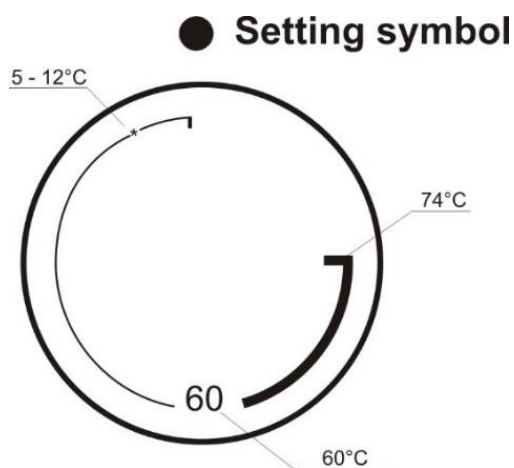

Figure 1

2 OPERATION AND FITTING INSTRUCTIONS

2.1 OPERATING CONDITIONS



The tank shall only be used in accordance with the conditions specified on the performance plate and in instructions for electric wiring. Besides legally acknowledged national regulations and standards, also conditions for connection defined in local electric and water works have to be adhered to, as well as the installation and operation manual. The room, in which the appliance will be operated, must be frost-free. The appliance has to be mounted at a convenient place, it means that the appliance must be easily available for potential necessary maintenance, repair or replacement, as the case may be.



If water is strongly calcareous, we recommend that any of the common decalcifying device was installed with the appliance, or the thermostat to be set to the minimum operation temperature of 60 °C. For proper operation, drinkable water of adequate quality shall be used.

2.2 WALL MOUNTING



Prior to the mounting, check the bearing capacity of the wall and the material it is made of, considering the weight of the heater filled with water. Depending on the wall material, choose adequate fixtures. We recommend entrusting wall mounting and anchoring to a specialist company or discussing the anchorage with an expert.

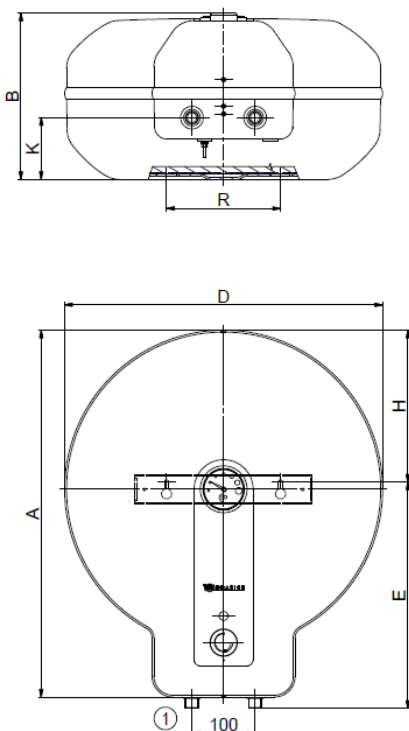

Figure 2

TO 20	
A	579
B	263
D	502
E	357
H	240
K	98
R	180
①	1/2" outer

TO 20		
VOLUME	l	20
MAX OPERATING OVERPRESSURE IN THE TANK	bar	6
ELECTRICAL CONNECTION	-	1/N/PE ~ 230 V / 50 Hz
INPUT	W	2200
EL. PROTECTION	-	IP 44
MAX OPERATING TEMPERATURE OF HOT WATER (HW)	°C	80
RECOMMENDED HOT WATER (HW) TEMPERATURE	°C	60
HEIGHT OF THE HEATER	mm	579
HEATER DIAMETER	mm	502
MAX WEIGHT OF THE HEATER WITHOUT WATER	kg	12
TIME OF EL. HEATING FROM 10°C TO 60°C *	hours	0.5
MIXED WATER V40	l	26.14
LOAD PROFILE	-	S
ENERGY EFFICIENCY CLASS	-	A
ENERGY EFFICIENCY	%	38
ANNUAL CONSUMPTION OF ELECTRIC ENERGY	kWh	485

Table 1



If the hot water heater is mounted in a **tight, small space**, or in an intermediate ceiling, etc., you have to make sure that the connecting side of the appliance (connections to water supply, area for electric plugging) remained accessible and no heat accumulation occurs. Free space of up to **600 mm** from the bottom edge of the heater has to be available under the heater. When mounted directly under the ceiling, the distance from the ceiling has to be **100 mm** at least

2.3 PLUMBING FIXTURE



The safety valve can be mounted both in vertical and horizontal position in the indicated direction of cold water flow. Safety valve is mounted on the cold water inlet identified with a blue ring.



The heater must be equipped with a membrane, spring-loaded safety valve. Safety valves with fixed pressure settings from the manufacturer are used for the assembly. Each individually lockable heater must be fitted with a cap on the cold water inlet, a test valve or a stopper to check the operation of the check valve, with a drain valve, a check valve and a safety valve (Figure 3). **The safety valve with a check valve is supplied with the heater.**



It is necessary to check the safety valve each time before putting it into operation. It is checked by manual moving of the membrane from the seat, turning the make-and-break device button always in the direction of the arrow. After being turned, the button must click back into a notch. Proper function of the make-and-break device results in water draining through the safety valve outlet pipe. In common operation, such a check needs to be implemented at least once a month, and after each heater shutdown for more than 5 days. Water may be dripping off the drain pipe of the safety valve; the pipe must be open into the air, pointed down; environment temperatures must not drop below zero.

Find necessary pressure values in the below - Table 2.

Heaters must be provided with a discharge valve mounted on the cold service water inlet to the heater for potential disassembly or repair. **When assembling the security equipment, follow the standard.**

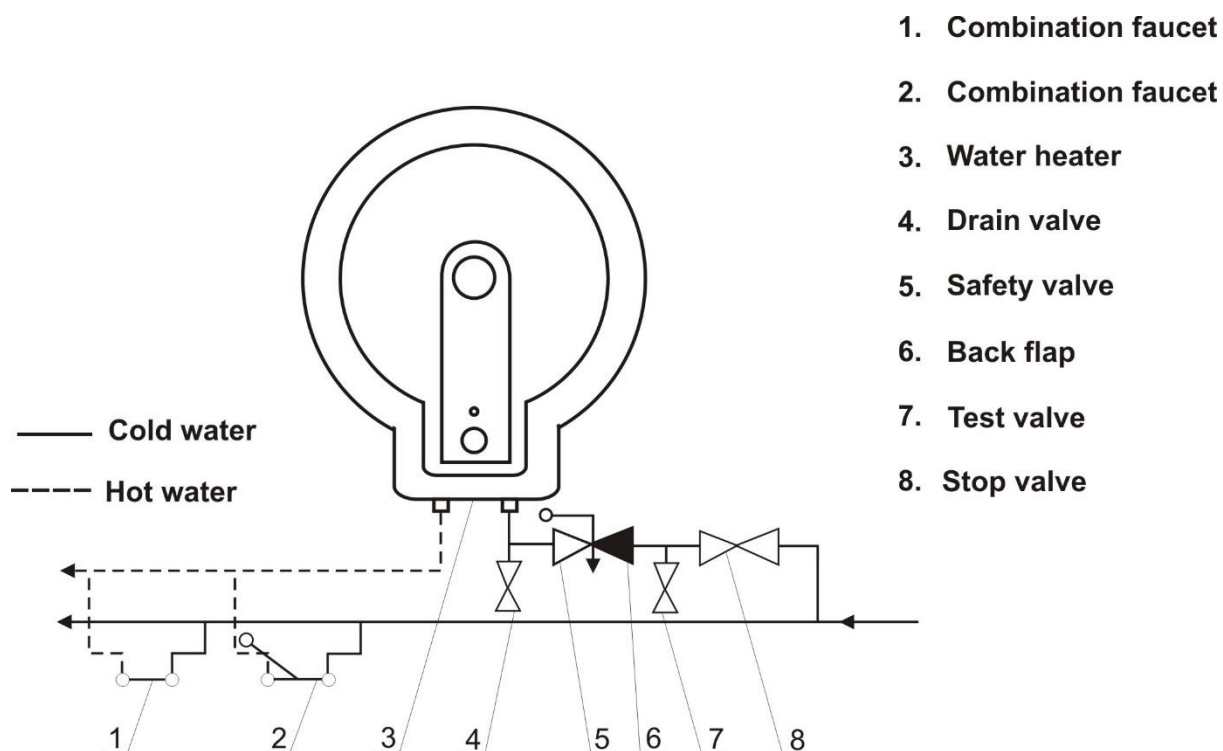

Figure 3

SAFETY VALVE STARTING PRESSURE [MPa]	ADMISSIBLE OPERATING WATER HEATER PRESSURE [MPa]	MAX. PRESSURE IN THE COLD WATER PIPE [MPa]
0.6	0.6	to 0.48

Table 2

2.4 ELECTRIC WIRING

2.4.1 ELECTRIC INSTALLATION GENERAL INFORMATION

The electric wiring scheme is attached to the water heater on the inner side of the removable front guard (Figure 4).

The degree of protection of electric parts of the heater is IP 44. Power input of electric element is 2200 W.

It is necessary to observe the below requirements during the electric wiring:



- The heater is connected to the 230V/50Hz electric network using a fixed moving conductor.
- Connection, repairs, and wiring inspections may only be implemented by a company (person) authorized to such activity. Expert connection must be confirmed on the warranty certificate
- The circuit must contain circuit breaker (protector).
- In order to enhance the protection of connection in bathrooms and shower inserts pursuant to Standard, the appliance is provided with a grounding terminal for connecting with a yellow-green protective conductor on minimum section 4 mm².
- To adjust the distance from the wall, connect the wire of the external protective bonding!
- Respect the rules of protection against electrical injuries in accordance with Standards.
- Access to the electric part of the heater is enabled only upon disconnecting the heater from power supply and unscrewing the guard of the heater.

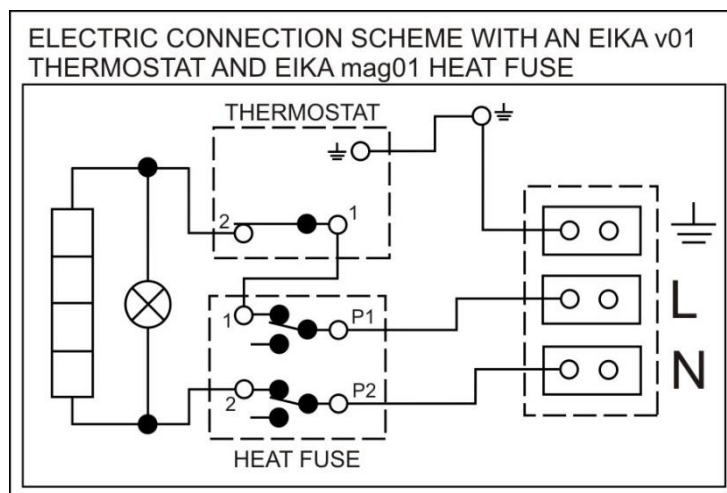

Figure 4



If the supply cord is damaged, it must be replaced by a company (person) authorized to such activity in order to avoid a hazard.

2.5 FIRST HEATER COMMISSIONING



Before opening the power supply, the tank must be filled with water. The process of first heating must be executed by licensed professional who has to check it. Both the hot water outlet pipe and safety armature parts may be hot.



During the heating process the pressurized connection water that increases its volume due to heating must drip off the safety valve. In non-pressurized connection water drips off the overflow combination faucet. When heating is finished, the set temperature and the actual temperature of consumed water should be roughly equal. After connecting the heater to the water main and electrical power system, and after checking the safety valve (following the instructions attached to the valve), the heater can be put into operation.

Procedure of putting the heater into operation:

1. Check the wiring and water supply; check correct position of the thermostat sensors, they have to be inserted all the way. The sensors must be inserted all the way in, first the operating and then the safety thermostat.
2. Open the hot water valve on the combination faucet.
3. Open the cold water inlet valve to the heater.
4. As soon as the water starts running through the hot water valve, the heater is filled, and the valve can be closed.
5. Prior to putting the heater into operation, screw on the front heater guard which closes the access to the electric compartment of the heater.
6. When hot service water heating by electric energy, switch on the power supply.
7. When commencing operation, flush the heater until the cloudiness in the water is gone.
8. Make sure to fill in properly the warranty certificate.

2.6 PUTTING OUT OF SERVICE, DISCHARGE



If the hot water heater is put out of service for a longer time, or if it is not going to be used it has to be drained and disconnected from the electric supply network. The switch for the supply lead or the fuse cut-outs have to be shut off.

At places with permanent risk of frost the hot water heater must be drained before the cold season starts if the appliance remains out of service for several days and if the power supply is disconnected.



Drainage of service water shall be performed after closing the shut-off valve in the cold water supply piping (through the discharge valve for safety valve combination), and with simultaneous opening of all hot water valves of connected fittings. **Hot water may outflow during the drainage!** If there is a risk of frost it has to be considered that not only the water in the hot water heater and in the hot water piping may get frozen but also the water in the entire cold water supply piping. It is therefore advisable to drain all fittings and piping that carry water, up to the part where the house water meter is installed (connection of the house to water main) which is not jeopardized by frost. When the tank is to be used again, it has to be filled with water and one needs to make sure that the water **flowing out at the hot water valves did not contain any bubbles.**

2.7 INSPECTION, MAINTENANCE & CARE FOR THE APPLIANCE



During the heating process the water that increases its volume during the heating must drip off the safety valve outlet (in non-pressurized connection this water drips off the combination faucet valve). In full heating (about 74 °C) the volumetric water gain is approx. 3% of the tank capacity. The function of the safety valve has to be checked regularly (based on the information contained in the attached safety valve manual). In common operation, such a check needs to be implemented at least once a month, and after each heater shutdown that exceeds 5 days.



Attention! In doing so, the cold water supply pipe and the connection fitting of the tank may get heated! If the hot water heater does not work, or if hot water is not withdrawn, no water shall drip off the safety valve. If water drips, then the pressure in the supply piping is either too high, or the safety valve is defective. Please call a specialized plumber immediately!



Repetitive water heating causes limestone sediment on both the enameled tank walls and chiefly the flange lid. The sedimentation depends on the hardness of water heated, its temperature, and amount of hot water consumed. **We recommend checking and cleaning the tank from scale and eventual replacement of the anode rod after two years of operation.**

The anode life is theoretically calculated for two years of operation; however, it changes with water hardness and chemical composition in the place of use. Based on such an inspection, the next term of anode rod exchange may be determined. Have the company in charge of service affairs clean and exchange the anode. When draining water from the heater, the combination faucet valve for hot water must be open, preventing occurrence of under-pressure in the heater tank which would stop the water from draining.

2.8 MOST FREQUENT FUNCTION FAILURES AND THEIR CAUSES

FAILURE SYMPTOM	LED	SOLUTION
Water in tank is cold	<ul style="list-style-type: none"> • Light on 	<ul style="list-style-type: none"> • Heating element failure
Water in the tank is not warm enough	<ul style="list-style-type: none"> • Light on 	<ul style="list-style-type: none"> • Heating element failure
Water in the tank is cold	<ul style="list-style-type: none"> • Light off 	<ul style="list-style-type: none"> • Thermostat failure - the safety fuse turned off electricity supply • Power supply outside the heater discontinued
Water in the tank does not correspond with temperature set		<ul style="list-style-type: none"> • Thermostat failure

Table 3



Do not try to repair the failure yourselves. Seek either expert or service help. It does not take much for an expert to remove the defect. When making a repair appointment, report the type and serial number you find on the performance plate of your water heater.

3 IMPORTANT NOTICES

3.1 INSTALLATION REGULATIONS

- **Without a confirmation of performed electrical and plumbing fixture issued by an authorized company the warranty certificate shall be void.**
- You have to apply for approval of a local power supplier to connect the heater.
- All hot water outlets must be provided with a combination faucet.
- It is not allowed to handle the thermostat in any manner whatsoever, aside from temperature resetting with a control button.
- All electric installation handling, setting, and regulation feature exchange, may only be implemented by an authorized service company.
- The thermal fuse must not be turned off. In case of thermostat defect, the thermal fuse interrupts electric power input to the heating element if the water temperature in the heater exceeds 90 °C.



Both the electric and water installation must follow and meet the requirements and regulations relevant in the country of use!

We would like to emphasize that the heater must not be connected to power supply if work involving flammable liquids (petrol, spot remover) or gases, etc., is performed nearby.

3.2 DISPOSAL OF PACKAGING MATERIAL AND FUNCTIONLESS PRODUCT

A service fee for providing return and recovery of packaging material has been paid for the packaging in which the water heater was delivered. The service fee was paid pursuant to Act No 477/2001 Coll., as amended, at EKO-KOM a.s. The client number of the company is F06020274. Take the water boiler packages to a waste disposal place determined by the town. When the operation terminates, disassemble and transport the discarded and unserviceable heater to a waste recycling center (collecting yard), or contact the manufacturer.



4 PRODUCT ACCESSORIES

The product is supplied with a safety valve G1/2", screws 6 x70 mm - 2 pcs, plastic dowels 12x60 mm - 2 pcs. The above parts are packed and placed in the packaging in the top part of the heater.

It is in your own interest to check the completeness of the accessories.

30-8-2021