

OPERATING AND INSTALLATION MANUAL

INDIRECT HOT WATER TANKS

OKH 100 NTR/HV
OKH 125 NTR/HV

OKH 100 NTR
OKH 125 NTR
OKH 160 NTR



Družstevní závody Dražice - strojírna s.r.o.
Dražice 69, 294 71 Benátky nad Jizerou
Phone.: +420 / 326 370 990
Fax: +420 / 326 370 980
e-mail: prodej@dzd.cz



CONTENTS

1	PRODUCT TECHNICAL SPECIFICATION.....	4
1.1	FUNCTION DESCRIPTION	4
1.2	ADVICE FOR CUSTOMERS	4
1.2.1	HOT WATER CONSUMPTION.....	4
1.2.2	ENERGY SAVING.....	4
1.3	DESIGN AND BASIC DIMENSIONS OF TANK.....	5
2	OPERATION AND FITTING INSTRUCTIONS.....	9
2.1	OPERATING CONDITIONS	9
2.2	PLUMBING FIXTURE.....	9
2.3	ELECTRICAL INSTALLATION.....	11
2.3.1	GENERAL INFORMATION FOR ELECTRICAL INSTALLATION	11
2.3.2	ELECTRONIC THERMOSTAT WIRING METHODS	11
2.4	CONNECTION OF INDIRECT TANK TO HOT WATER SYSTEM.....	12
2.5	FIRST COMMISSIONING.....	13
2.6	PUTTING OUT OF SERVICE, DISCHARGE	13
2.7	INSPECTION, MAINTENANCE & CARE FOR THE APPLIANCE	14
2.8	MOST FREQUENT FUNCTION FAILURES AND THEIR CAUSES	15
3	OPERATION OF THERMOSTAT	15
3.1	SERVICING.....	15
3.1.1	OPERATING DEVICES OF THE TANK	15
3.1.2	TEMPERATURE SETTING	16
4	IMPORTANT NOTICES.....	16
4.1	INSTALLATION REGULATIONS.....	16
4.2	SPARE PARTS.....	17
4.3	DISPOSAL OF PACKAGING MATERIAL AND NON-FUNCTIONING PRODUCT.....	17

PRIOR TO THE INSTALLATION OF THE TANK, READ CAREFULLY THIS MANUAL!

Dear Customer,

The Works Cooperative of Dražice – Machine Plant, Ltd., would like to thank you for your decision to use a product of our brand. The present instructions will introduce you to the use, construction, maintenance and other information regarding electrical water tanks.



The manufacturer reserves the right for engineering modification of the product. The product is designed for permanent contact with drinkable water.

It is recommended to use the product in indoor environment with air temperatures from +2°C to 45°C and a relative humidity up to 80%.

Product's reliability and safety is proven by tests implemented by the Engineering Test Institute in Brno.

Meaning of pictograms used in the Manual



Important information for tank users.



Abiding by the recommendations of the manufacturer serves to ensure trouble-free operation and the long service life of the product.



Caution!

Important notice to be observed.

1 PRODUCT TECHNICAL SPECIFICATION

1.1 FUNCTION DESCRIPTION

Indirect stationary NTR and NTR/HV series tanks are used to prepare HSW in combination with another hot water supply, mostly gas boiler. Their rated power output guarantee sufficient amount of HSW even for large dwelling units - premises, restaurants and similar facilities. **In case of higher HSW consumption tanks heat water continuously and operate in a manner that is similar to that of instantaneous tanks.**

1.2 ADVICE FOR CUSTOMERS

1.2.1 HOT WATER CONSUMPTION



Consumption of hot water in households depends on the number of people, amount of sanitary equipment, length, diameter and insulation of piping in the flat, or on individual habits of users.

1.2.2 ENERGY SAVING



Hot utility water reservoir is insulated by means of top-quality polyurethane foam with zero CFCs content.

Set the temperature on the tank thermostat to that you need for the operation of your household. Thus you will reduce electricity consumption, as well as the amount of lime sediments on the walls of the receptacle and on the heat exchanger.

Benefits of using indirect tank:

- Easy installation and connection to hot water supply,
- Very fast hot utility water heating,
- Enamelled steel tank ensures compliance with all hygienic requirements for the quality of HSW,
- Integrated protective magnesium anode increases corrosion resistance,
- Quality polyurethane insulation ensures minimum heat losses,
- Smoothly settable HSW temperature up to 74°C,
- multiple supply points,
- Light indication of tank's run,
- Accurate HSW temperature control,
- Possibility of connecting HSW circulation.

1.3 DESIGN AND BASIC DIMENSIONS OF TANK

The tank receptacle is made of steel plate and tested at 0.9 MPa of overpressure. The inside of the receptacle is enamelled. A flange is welded onto the lower bottom of the receptacle with a flange lid screwed onto it. A sealing ring is inserted between the flange lid and the flange. Thermowells for thermostat sensors and thermometer installation are placed in the flange lid. An anode rod is mounted onto the M8 nut. **The water reservoir is insulated by means of polyurethane foam.** Electric wiring is placed underneath the plastic removable cover. The temperature of water can be set using the thermostat. Heat exchanger is welded in pressure receptacle.

Technical description: OKH 100 NTR, OKH 125 NTR, OKH 160 NTR

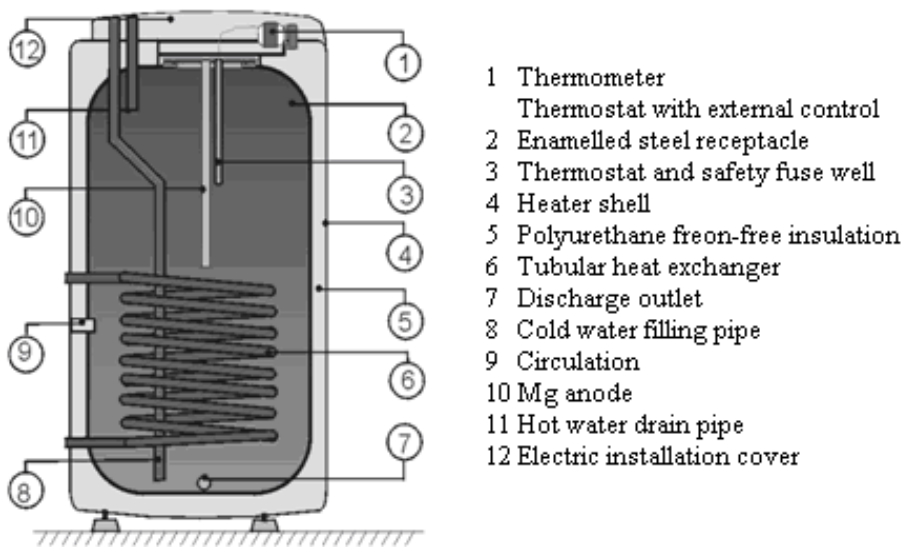

Figure 1

Technical description: OKH 100 NTR/HV, OKH 125 NTR/HV

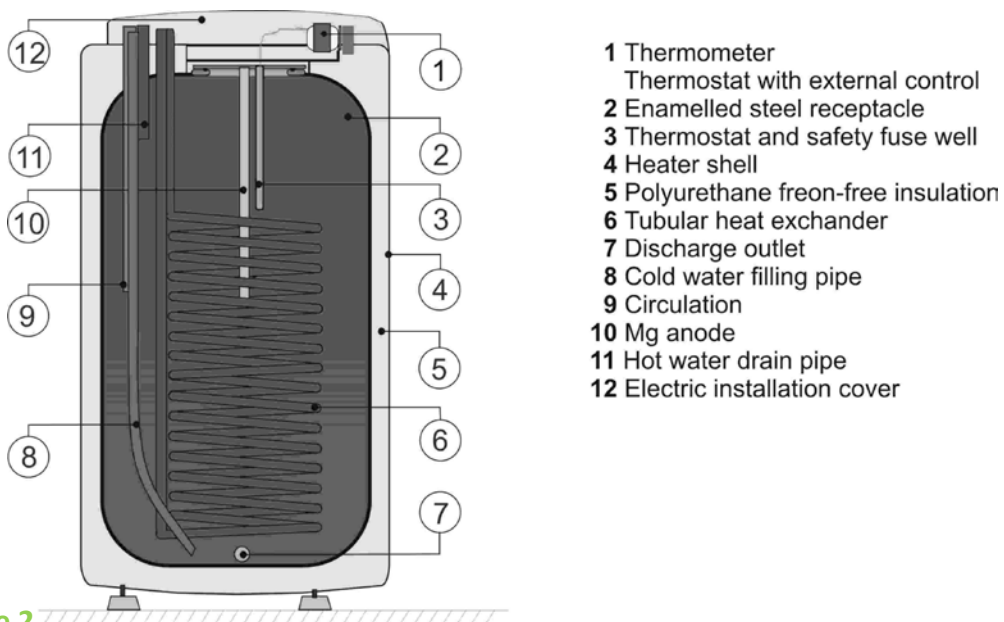

Figure 2

Dimensions of tanks

OKH 100 NTR, OKH 125 NTR, OKH 160 NTR

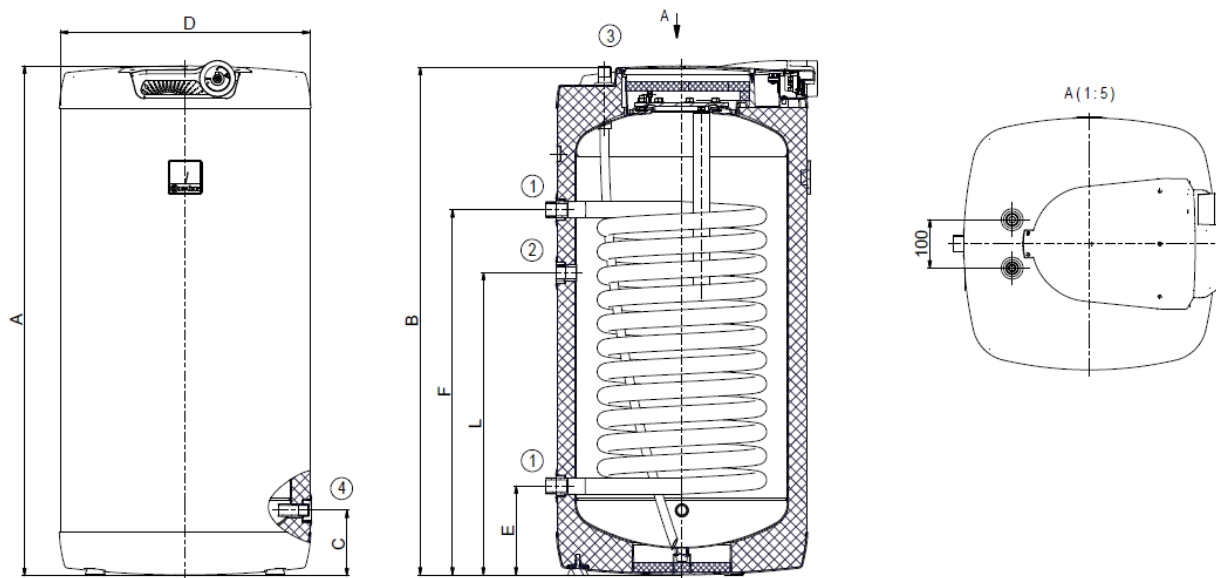
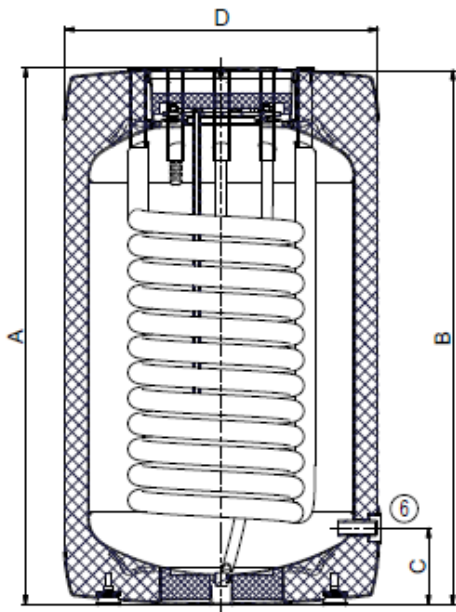

Figure 3

	A [mm]	B [mm]	C[mm]	D[mm]	E[mm]	F[mm]	L[mm]
OKH 100 NTR	885	882	129	520	182	622	522
OKH 125 NTR	1050	1047	129	520	182	752	622
OKH 160 NTR	1235	1233	129	520	182	752	882

neck # 1	1" outer
neck # 2	3/4" inner
neck # 3	3/4" outer
neck # 4	1/2" inner

OKH 100 NTR/HV, OKH 125 NTR/HV



neck # 1	3/4" outer
neck # 2	3/4" outer
neck # 3	3/4" outer
neck # 4	3/4" outer
neck # 5	3/4" outer
neck # 6	1/2" inner

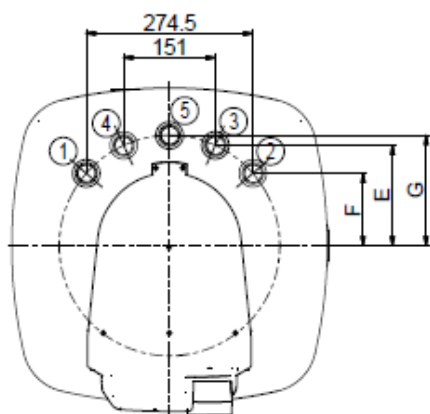

	A [mm]	B [mm]	C[mm]	D[mm]	E[mm]	F[mm]	G[mm]
OKH 100 NTR/HV	885	882	127	520	165	119	182
OKH 125 NTR/HV	1050	1047	127	520	165	119	182

Figure 4

TECHNICAL DATA

TYPE		OKH 100 NTR	OKH 125 NTR	OKH 160 NTR	OKH 100 NTR/HV	OKH 125 NTR/HV
VOLUME	L	95	120	160	95	120
MAX WEIGHT OF THE TANK WITHOUT WATER	kg	57	71	78	56	70
EXCHANGER HEAT TRANSFER SURFACE	m ²	1,08	1,45	1,45	1,08	1,45
MAXIMUM PRESSURE OF THE RECEPTACLE	MPa			0,6		
MAXIMUM PRESSURE OF THE EXCHANGER	MPa			1		
MAXIMUM HSW TEMPERATURE	°C			80		
RECOMMENDED HSW TEMPERATURE	°C			60		
HSW CONNECTION				G ¾"		
HEATING WATER CONNECTION		G 1"	G 1"	G 1"	G ¾"	G ¾"
ELECTRICAL PROTECTION				IP42		
CONNECTING VOLTAGE				1 PEN AC 230V. 50 Hz		
RATED THERMAL OUTPUT AT HEATING WATER TEMPERATURE 80°C AND FLOW 720 l/h	W	24000	32000	32000	24000	32000
TIME OF HEATING BY EXCHANGER FROM 10°C TO 60°C	min	14	14	17	14	14
STATIC LOSS	W	42	49	54	42	49

Table 1

2 OPERATION AND FITTING INSTRUCTIONS

2.1 OPERATING CONDITIONS



The tank shall only be used in accordance with the conditions specified on the power plate and in instructions for electric wiring. Besides legally acknowledged national regulations and standards, also conditions for connection defined in local electric and water works have to be adhered to, as well as the installation and operation manual. The room, in which the appliance will be operated, must be frost-free. The appliance has to be mounted at a convenient place, it means that the appliance must be easily available for potential necessary maintenance, repair or replacement, as the case may be.

We emphasize that the tank shall not be connected to power supply if flammable liquids (benzine, stain cleaner) or gases, etc., are handled in its proximity.



If water is strongly calcareous we recommend that any of the common decalcifying devices was installed with the appliance, or that the thermostat was set to the minimum operating temperature of 60°C. For proper operation, drinkable water of adequate quality shall be used. To avoid potential deposits we recommend that water filter is connected in series with the tank.

2.2 PLUMBING FIXTURE



Tanks are connected to plumbing fixtures as shown in Figure 5. For potential disconnection of the tank, utility water inlets and outlets must be provided with Js 3/4" screw coupling. If the hot utility water (HSW) distribution is equipped with circulation circuit, the reverse pipe is connected to the inlet identified as CIRCULATION. The 100, 125, 160 NTR and 100, 125 NTR / HV types are equipped with a discharge outlet. The tank shall be equipped with safety valve to ensure operation. The safety valve is mounted on the cold water inlet identified with a blue ring.



Every hot utility water pressure tank shall be equipped with membrane spring loaded with safety valve. Safety valve shall be easily accessible, fitted as close as possible to the tank. Supply piping shall have minimum inside diameter identical with that of safety valve. Safety valve is placed high enough to secure dripping water drain by gravity. We recommend mounting the safety valve onto a branch pipe. Easier exchange without the necessity of draining water from the tank. Safety valves with fixed pressure settings from the manufacturer are used for the assembly. The starting pressure of the safety valve must be identical to the maximum allowed pressure of the tank, and at least 20 % higher than is the maximum pressure in the water main (Table 2). If the water main pressure exceeds such value, a reduction valve must be added to the system. No closing armature may be mounted between the tank and the safety valve. During assembly, follow the guide provided by the safety equipment manufacturer.



It is necessary to check the safety valve each time before putting it into operation. It is checked by manual moving of the membrane from the seat, turning the make-and-break device button always in the direction of the arrow. After being turned, the button must click back into a notch. Proper function of the make-and-break device results in water draining through the safety valve outlet pipe. In regular operation, such a check needs to be carried out at least once a month, and after each shutdown of the tank longer than 5 days. Water may be dripping off the drain pipe of the safety valve; the pipe must be open into the air, pointed down; environment temperatures must not drop below zero. When draining the tank, use the recommended drain valve. First of all, close water inlet in the tank. Find necessary pressure values in the following table. For proper safety valve operation, a backflow valve shall be mounted on the inlet pipes, preventing spontaneous heater draining of the tank and hot water penetration back into the water main.

Required pressures - Table 2 - We recommend that the hot water distribution from the tank is as short as possible in order to reduce heat losses

SAFETY VALVE STARTING PRESSURE (MPa)	ACCEPTABLE OPERATING OVER-PRESSURE OF THE TANK (MPa)	MAX COLD WATER PRESSURE IN PIPING (MPa)
0,6	0,6	up to 0.48
0,7	0,7	up to 0.56
1	1	up to 0.8

Table 2

Connection of tank exchanger (left, right) and fixture armature at cold water inlet.

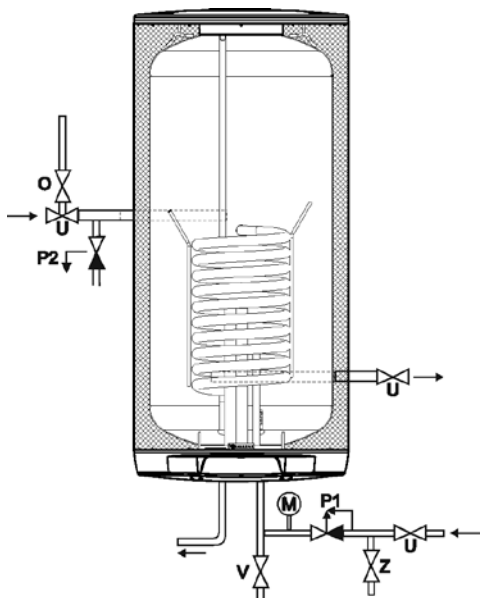

- O - bleeder valve
- U - shutoff valve
- P1 - Safety valve with backflow flap
- P2 - safety valve for heating circuit
- M - Manometer
- Z - Test valve
- V - Drain valve

Connection on cold water inlet must comply with the standard effective in the country of installation.

Figure 5

2.3 ELECTRICAL INSTALLATION

2.3.1 GENERAL INFORMATION FOR ELECTRICAL INSTALLATION



- Check the insertion of the thermostat sensor in the thermowell, the so-called insertion all the way.
- The tank can be connected to any hot water heating boiler up to the 50 kW power output.
To adjust the distance from the wall, connect the wire of the external protective bonding!
- The tank is powered directly from boiler by control voltage 230 V/50 Hz.
- Elastic cable CYSY 4Cx0.75 can be used for cross connection.
- Connecting terminals are identified on the tank's terminal board.

2.3.2 ELECTRONIC THERMOSTAT WIRING METHODS

Wiring of tanks of the below types:

OKH 100 NTR, OKH 125 NTR, OKH 160 NTR, OKH 100 NTR/HV, OKH 125 NTR/HV

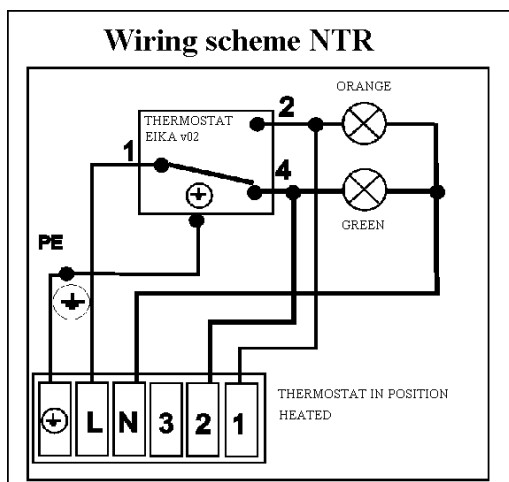

- there is voltage on terminal 2 if tank is heated
- there is voltage on terminal 1 if tank is not heated

Figure 6



Touch thermometer is installed on the control panel to control the temperature of water, additionally there is a capillary thermostat to set the desired water temperature and two signal lights: "green" = tank heated; "orange" = tank is getting heated.

2.4 CONNECTION OF INDIRECT TANK TO HOT WATER SYSTEM



It is recommended that heating water inlet and outlet are provided with shutoff valves (in case the tank has to be demounted). Valves should be as close as possible to the tank to minimise heat losses.

The heating circuit shall be connected to marked tank exchanger inputs and outputs, and bleeder valve installed at the highest point. It is necessary to install a filter into the circuit in order to protect pumps, three-way valve, backflow flaps and the exchanger from sedimentation. It is recommended to flush the heating circuit before the assembly. All wiring connections must be properly insulated from heat. If the system works with priority heating of HSW using a three-way valve, always follow the installation instructions of the three-way valve's manufacturer.



To connect the tank to water supply system, hot water heating system, power supply and, after testing the safety valve (accordingly with the manual attached to the valve), the tank can be put in operation. Before opening the power supply, the tank must be filled with water. The process of first heating must be executed by licensed professional who has to check it. Both the hot water outlet pipe and safety armature parts may be hot.

Example of connecting the tank to water and heating system

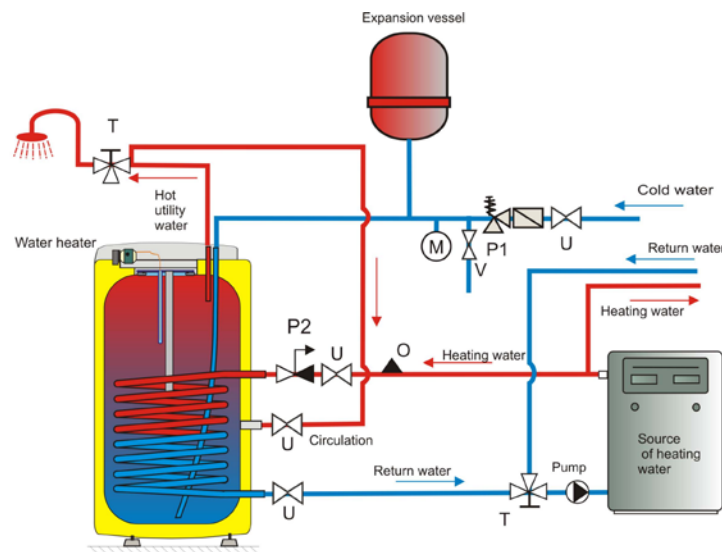

- U - Shut-off valve
- P1 - Pressure relief valve with backflow valve
- P2 - Pressure relief valve for rating circuit
- V - Drain valve
- M - Manometer
- T - Three-way valve
- O - Bleeder valve

* Use of an expansion vessel is not a condition correct connection only an alternative solution.

Figure 7

2.5 FIRST COMMISSIONING



To connect the tank to water supply system, hot water heating system, power supply and, after testing the safety valve (accordingly with the manual attached to the valve), the tank can be put in operation. Before opening the power supply, the tank must be filled with water. The process of first heating must be executed by licensed professional who has to check it. Both the hot water outlet pipe and safety armature parts may be hot.



During the heating process the pressurised connection water that increases its volume due to heating must drip off the safety valve. In non-pressurised connection water drips off the overflow combination faucet. When heating is finished, the set temperature and the actual temperature of consumed water must be more-or-less the same. Once the tank is connected to water supply system and power supply, and the safety valve tested (accordingly with the manual attached to the valve), the tank can be put in operation.

Putting the tank in operation:

1. Check both water and electric installation; for combined tanks, check also the installation to the hot water heating system. Check proper placement of thermostat sensors. The sensors in the thermowell have to be inserted all the way.
2. Open the hot water valve on the combination faucet.
3. Open the cold water inlet valve to the tank.
4. Once water starts draining through the hot water valve, filling of the tank is completed and the valve can be closed.
5. In case of leakage (of flange lid), we recommend that the flange lid bolts are fastened.
6. Screw down the electric installation guard.
7. When heating utility water with heat energy from the hot water heating system, open the heating water inlet and outlet valves, or de-aerate the exchanger.
8. Once the operation restarts, keep flushing the tank until the cloud disappears.
9. Make sure to fill in properly the warranty certificate.

2.6 PUTTING OUT OF SERVICE, DISCHARGE



If the hot water tank is put out of service or is not used for longer time, it has to be emptied and disconnected from power supply at all poles. The switch for the supply lead or the fuse cut-outs have to be shut off.

In locations that are permanently exposed to frost, hot water tank shall be emptied prior to the beginning of cold season, if the appliance is not used for several days, and if power supply is disconnected.



Drainage of utility water shall be performed after closing the shut-off valve in the cold water supply piping (through the discharge valve for safety valve combination), and with simultaneous opening of all hot water valves of connected fittings. **Hot water may outflow during the drainage!** If there is a risk of frost, be aware that not only the water in the hot water tank and the water in the hot water piping may freeze, but also the water in the entire cold water supply piping. It is therefore advisable to drain all fittings and piping that carry water, up to the part where the house water meter is installed (connection of the house to water main) which is not jeopardised by frost. When the tank is to be used again, it has to be filled with water and one needs to make sure that the **water flowing out at the hot water valves did not contain any bubbles.**

2.7 INSPECTION, MAINTENANCE & CARE FOR THE APPLIANCE



During the heating process the water that increases its volume during the heating must drip off the safety valve outlet (in non-pressurised connection this water drips off the combination faucet valve). In full heating (about 65°C) the volumetric water gain is approx. 3% of the tank capacity. The function of the safety valve has to be checked regularly (based on the information contained in the attached safety valve manual). In regular operation, such a check needs to be carried out at least once a month and then after each shutdown of the tank that lasts over 5 days.

Caution! In doing so, the cold water supply pipe and the connection fitting of the tank may get heated! If the hot water tank is not in run, or hot water is not consumed, no water may drip off the safety valve. If water drips, then the pressure in the supply piping is either too high, or the safety valve is defective. Please call a specialised plumber immediately!



If water contains too many minerals, an expert has to come to remove the scale that forms inside the tank, as well as free sediments. This has to be performed after one or two years of operation. Repeated heating causes lime scale settling on the receptacle walls and mostly on the lid of the flange. Lime scale settling depends on hardness of heated water, its temperature and on the volume of hot water used.

We recommend checking and cleaning the tank from lime scale and eventual replacement of the anode rod after two years of operation. The anode life is theoretically calculated for two years of operation; however, it changes with water hardness and chemical composition in the place of use. Based on such an inspection, the next term of anode rod exchange may be determined. Have a company in charge of service affairs deal with the cleaning and exchanging of the anode.

When draining water from the tank, the combination faucet valve for hot water must be open, preventing the occurrence of under-pressure in the tank receptacle which would stop water from draining. Cleaning is carried out through the hole in the flange by: draining the boiler, dismantling the flange lid and cleaning the tank. A new sealing has to be used for re-fitting. Since the inside of the tank has special enamel the surface of which must not get in contact with the scale removing agent – do not work with a lime pump. Remove the lime layer with a timber and suck it off, or wipe it off with a clout. After that, the appliance must be rinsed thoroughly and the heating process is checked the same as during the initial putting in operation. Do not use any abrasive cleaning agents or dye thinners (such as cellulose thinner, trichlor, and the like) to clean the outer shell of the tank. For cleaning use a wet clout and add a few drops of liquid cleaning agent for household applications.

2.8 MOST FREQUENT FUNCTION FAILURES AND THEIR CAUSES

FAILURE SYMPTOM	INDICATOR	SOLUTION
Temperature of water is not corresponding with the set value		<ul style="list-style-type: none"> Defective thermostat
Water is constantly dripping off the safety valve	<ul style="list-style-type: none"> LED is not on 	<ul style="list-style-type: none"> high input pressure defective safety valve

Table 3



Do not attempt to repair the failure yourselves. Seek either expert or service help. It does not take much for an expert to remove the defect. When organizing repair state the model designation and serial number that is to be found on the power plate of your water tank.

3 OPERATION OF THERMOSTAT

3.1 SERVICING

3.1.1 OPERATING DEVICES OF THE TANK

Thermostat's control panel

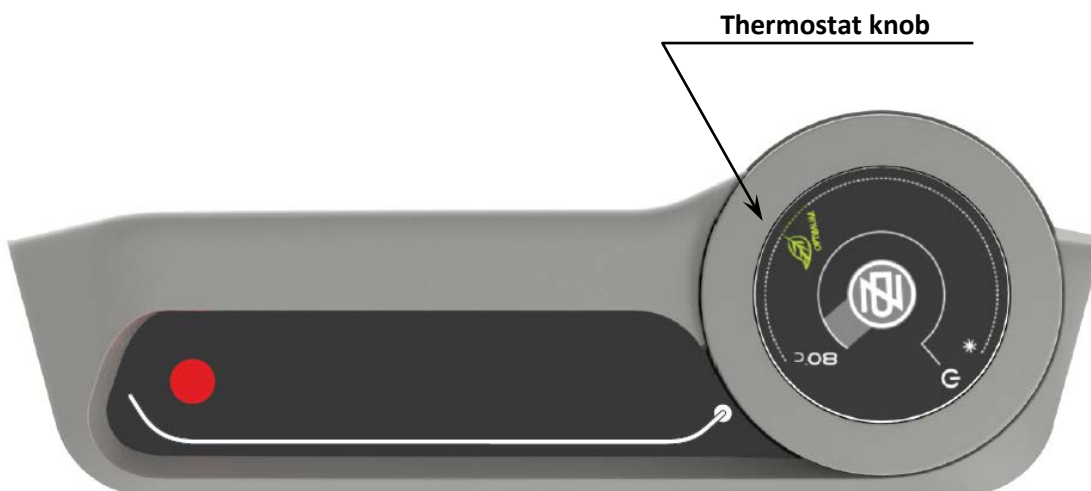

Figure 8

3.1.2 TEMPERATURE SETTING

Water temperature is set by turning the thermostat knob. The desired symbol is adjusted against the fixed point on the control panel (Figure 9).

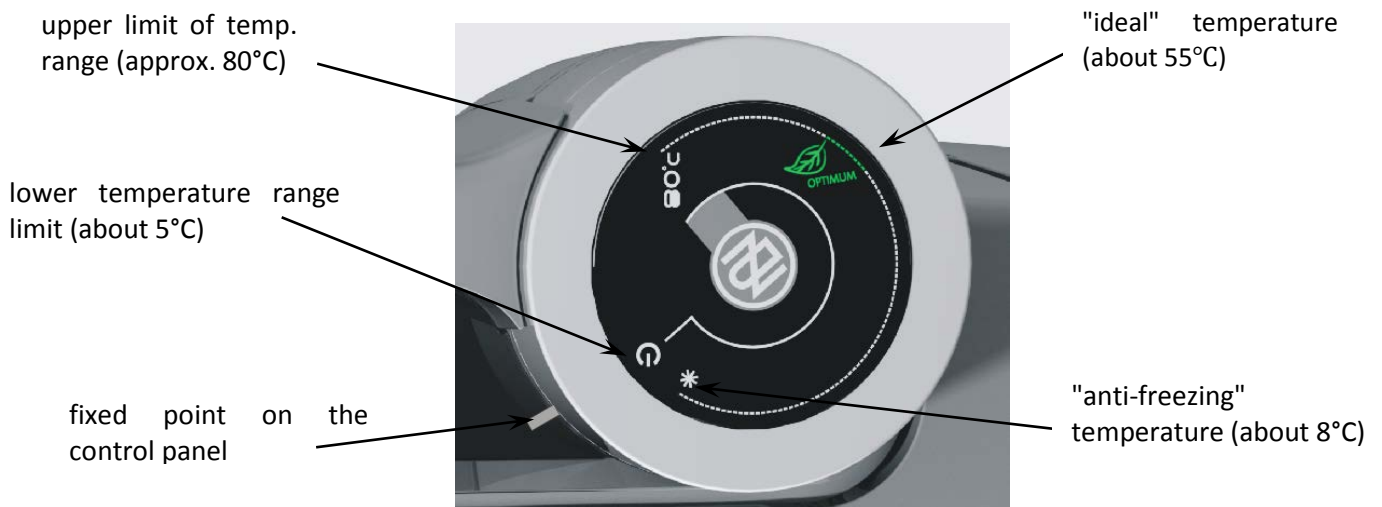

Figure 9



Adjusting the thermostat knob to the left backstop does not mean permanent shutoff of the heating element. When the tank is in use without blocking the daily rate, we do not recommend the temperature to be set above 55°C. Select the "OPTIMUM" symbol as the maximum.

4 IMPORTANT NOTICES

4.1 INSTALLATION REGULATIONS

- Check and exchange the Mg anode regularly.
- **No closing armature may be mounted between the tank and the safety valve.**
- If the overpressure in the eater main exceeds 0.6 MPa, a reduction valve must be mounted before the safety valve.
- All outlets of hot water must be equipped with a combination faucet.
- Prior to the first filling the tank with water we recommend that the receptacle's flange connection nuts are tightened.
- It is not allowed to handle the thermostat, aside from temperature resetting with a control button.
- All electric installation handling, setting, and regulation feature exchange, may only be implemented by a service company.



Both the electric and water installation must follow and meet the requirements and regulations relevant in the country of use!

We emphasize that the tank shall not be connected to power supply if flammable liquids (benzine, stain cleaner) or gases, etc., are handled in its proximity.

4.2 SPARE PARTS

G 3/4" safety valve is packed with the product and the OKH 100, 125, 160 NTR and OKH 100, 125 NTR/ HV types are additionally equipped with a discharge valve.

It is in your own interest to check the completeness of the accessories.

4.3 DISPOSAL OF PACKAGING MATERIAL AND NON-FUNCTIONING PRODUCT

A service fee for providing return and recovery of packaging material has been paid for the packaging in which the product was delivered. The service fee was paid pursuant to Act No 477/2001 Coll., as amended, at EKO-KOM a.s. The client number of the company is F06020274. Take the water tank packages to a waste disposal place determined by the municipality. When the operation terminates, disassemble and transport the discarded and unserviceable heater to a waste recycling centre (collecting yard), or contact the manufacturer.



31-3-2016