

OPERATING AND INSTALLATION MANUAL

STATIONARY ELECTRICAL HOT WATER TANKS



OKCE 100 NTR/2,2 kW
OKCE 125 NTR/2,2 kW

Družstevní závody Dražice - strojírna s.r.o.
Dražice 69, 294 71 Benátky nad Jizerou
Phone.: +420 /326 370 990
Fax: +420 / 326 370 980
e-mail: prodej@dzd.cz



CONTENTS

1	PRODUCT TECHNICAL SPECIFICATION.....	4
1.1	FUNCTION DESCRIPTION	4
1.2	PRODUCT DESCRIPTION	4
1.3	DESIGN AND BASIC DIMENSIONS OF TANK.....	5
1.4	TECHNICAL PARAMETERS.....	6
2	OPERATION AND FITTING INSTRUCTIONS.....	7
2.1	OPERATING CONDITIONS	7
2.2	ELECTRICAL INSTALLATION.....	7
2.2.1	ELECTRIC INSTALLATION FOR: OKCE 100 S/2.2 kW; OKCE 125 S/2.2 kW;.....	7
2.3	PLUMBING FIXTURE.....	8
2.4	PRESSURE LOSSES.....	9
2.5	CONNECTION OF INDIRECT TANK TO HOT WATER SYSTEM.....	9
2.6	EXAMPLES OF tanks CONNECTION.....	10
2.7	FIRST COMMISSIONING.....	12
2.8	CLEANING OF TANK AND EXCHANGE OF ANODE ROD.....	12
2.9	SPARE PARTS.....	13
3	OPERATION OF THERMOSTAT	13
3.1	SERVICING.....	13
3.1.1	OPERATING DEVICES OF THE HEATER	13
3.1.2	TEMPERATURE SETTING	13
3.2	MOST FREQUENT FUNCTION FAILURES AND THEIR CAUSES	14
4	IMPORTANT NOTICES.....	15
4.1	INSTALLATION REGULATIONS.....	15
4.2	DISPOSAL OF PACKAGING MATERIAL AND NON-FUNCTIONING PRODUCT.....	16

CAREFULLY READ THIS MANUAL BEFORE INSTALLING THE WATER HEATER!

Dear Customer,

The Works Cooperative of Dražice – Machine Plant, Ltd., would like to thank you for your decision to use a product of our brand. With this guide, we will introduce you to the use, construction, maintenance and other information on electrical water heaters.



The manufacturer reserves the right for engineering modification of the product. The product is designed for permanent contact with drinkable water.

It is recommended to use the product in indoor environment with air temperatures from +2°C to 45°C and a relative humidity up to 80%. 80%.

Product's reliability and safety is proven by tests implemented by the Engineering Test Institute in Brno.

Meaning of pictograms used in the Manual



Important information for heater users.



Abiding by the recommendations of the manufacturer serves to ensure trouble-free operation and the long service life of the product.



Caution!

Important notice to be observed.

1 PRODUCT TECHNICAL SPECIFICATION

1.1 FUNCTION DESCRIPTION

The construction of the OKC 100,125 NTR series tanks and their variety allow economic preparation of hot service water (HSW) using different energy sources. Their nominal performance provides sufficient amount of hot water for flat units, premises, restaurants, and similar establishments. HSW can be heated by electric energy, different types of central heating boilers, and combinations of those.

Service water heating via thermal energy through heat exchanger

Closing valves of the heat exchanger must be opened which ensures heating water flow from the hot water heating system. Together with a closing valve, it is recommended to install an air outlet valve at the inlet to the heat exchanger in order to bleed the heat exchanger as needed, in particular before the beginning of the heating season. The time it takes to heat up using the heat exchanger depends on the temperature and flow of water in the hot water heating system.

1.2 PRODUCT DESCRIPTION

The tank receptacle is welded from a steel plate; the exchangers from a steel tube and, as a unit, it is entirely coated with hot water resistant enamel. A flange is welded onto the upper bottom of the receptacle with a flange lid screwed to it. A sealing ring is inserted between the flange lid and the flange.

Thermowells for placing a heating element and sensors of regulation thermostat and safety fuse are located in the flange lid. Electric wiring is placed underneath the plastic removable cover. The temperature of water can be set using the thermostat.

For additional corrosion protection a magnesium anode is mounted in the upper part of the tank to adjust the electric potential inside the receptacle, thus reducing the risk of its corrosion. Tanks have hot and cold water outlets welded on, and a circulation opening. The tank is insulated with polyurethane foam of 40 - 65 mm thickness. The shell of the tank is steel plate coated with powder dye; connecting pieces are metal coated. The entire heater stands on three rectification screws with a possibility of levelling floor unevenness within the range of 10 mm. The heater is to be placed on the ground. The receptacle is tested with pressure of 0.9 MPa, and exchangers with pressure of 1.5 MPa.

NTR version has one heat exchanger located in the lower part of the tank, and uses one source of heating water for heating.

1.3 DESIGN AND BASIC DIMENSIONS OF TANK

OKCE 100 NTR/2,2 kW, OKCE 125 NTR/2,2 kW

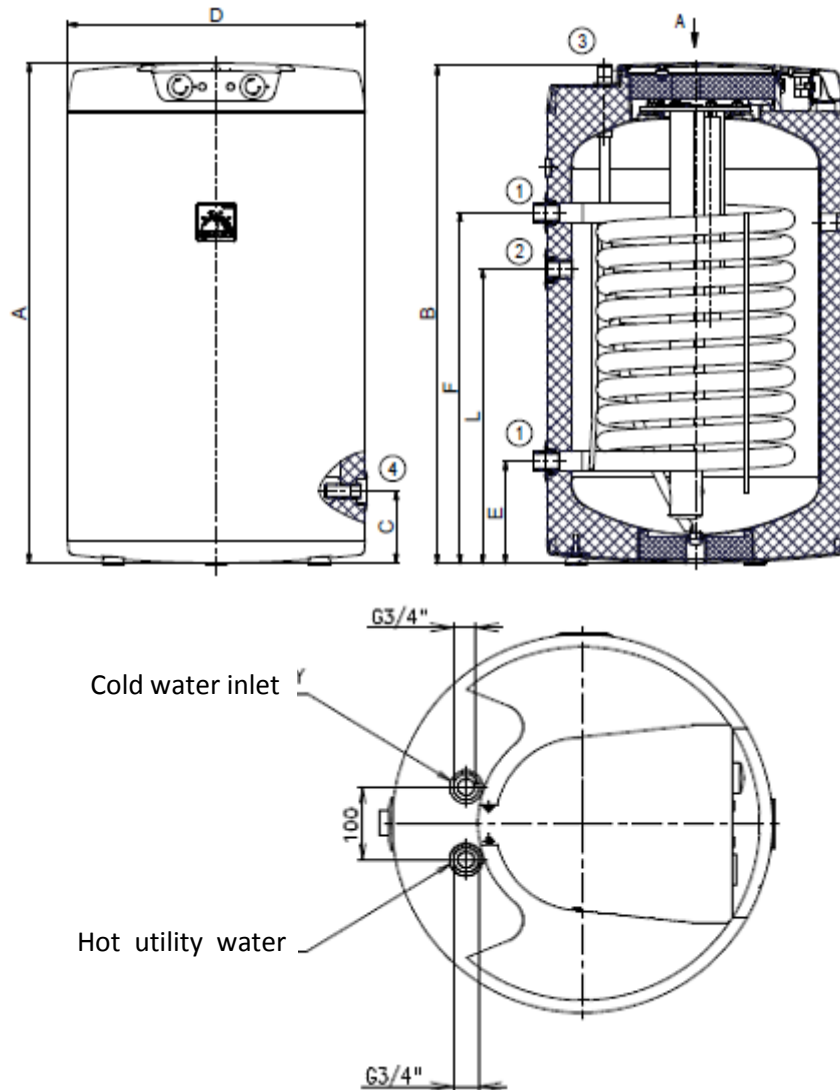

Figure 1

Typ	OKCE 100 NTR/2,2 kW	OKCE 125 NTR/2,2 kW
A	902	1062
B	893	1059
C	145	145
D	524	524
E	195	195
F	635	765
L	535	635

①	1" outer
②	3/4" inner
③	3/4" outer
④	1/2" inner

1.4 TECHNICAL PARAMETERS

MODEL	OKCE 100 NTR/2,2kW	OKCE 125 NTR/2,2 kW
Capacity [l]	88	113
Weight without water [kg]	59	71
TANK OPERATING PRESSURE [MPa]		0,6
HEAT EXCHANGER OPERATING PRESSURE [MPa]		1
MAX TEMPERATURE OF HEATING WATER [°C]		110
MAX TEMPERATURE OF HOT WATER [°C]		80
Heating surface of bottom heat exchanger [m ²]	1	1,45
BOTTOM HEAT EXCHANGER POWER AT HEATING WATER TEMPERATURE OF 80 °C AND FLOW OF 720 l/h [kW]	24	32
PERMANENT HOT WATER POWER [l/h]	610	990
TIME OF HEATING BY EXCHANGER FROM 10°C TO 60 °C [min]	14	14
TIME OF HEATING BY ELECTRICITY FROM 10°C TO 60 °C [h]	3	3,5
INPUT [kW]		2,2
ELECTRICAL CONNECTION OF CONTROL ELEMENTS		1 PE-N 230 V/50 Hz
ELECTRICAL PROTECTION		IP 42
STATIC LOSS [W]	42	54

Table 1

2 OPERATION AND FITTING INSTRUCTIONS

2.1 OPERATING CONDITIONS



The tank shall only be used in accordance with the conditions specified on the power plate and in instructions for electric wiring. Besides the legally acknowledged national regulations and standards, also conditions for connection defined in the local electric and water works have to be adhered to, as well as the installation and operation manual.

The temperature at the place of the tank installation must be higher than +2°C; and the room must not freeze. The appliance has to be mounted at a convenient place; it means that the appliance must be easily available for potential necessary maintenance, repair or replacement, as the case may be.



If water is strongly calcareous we recommend that any of the common decalcifying devices was installed with the appliance, or that the thermostat was set to the minimum operating temperature of 60°C (setting to position “ECO”). For proper operation, drinkable water of adequate quality shall be used. To avoid potential sediments we recommend that the device was installed together with a water filter.

2.2 ELECTRICAL INSTALLATION

2.2.1 ELECTRIC INSTALLATION FOR: OKCE 100 S/2.2 KW; OKCE 125 S/2.2 KW;

The wiring diagram is attached to the tank on the side of the electric installation guard.

Connection, repairs, and wiring inspections may only be carried out by a company authorised to such activity.

Expert connection must be confirmed on the warranty certificate.

The tank is connected to the 230 V/50 Hz electrical network using a fixed moving conductor with a switch that turns off all network poles and the circuit breaker (protector). The degree of protection of electric parts of the heater is IP 44.

Wiring diagram:

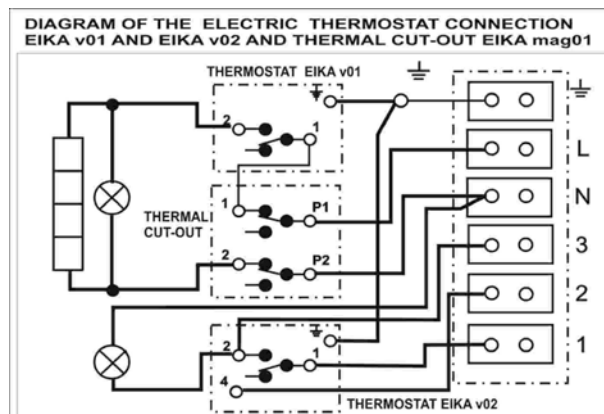

Figure 2

2.3 PLUMBING FIXTURE



Power water connects to pipes with ¾" thread in the bottom part of the tank. Blue - cold water supply, red – hot water outlet. For potential disconnection of the tank, the sanitary water inlets and outlets must be provided with screw coupling Js 3/4". The safety valve is mounted on the cold water inlet identified with a blue ring.



Every hot utility water pressure tank shall be equipped with membrane spring loaded with safety valve. Nominal clearance of safety valves is defined by standard. Safety valve shall be easily accessible, fitted as close as possible to the tank. The inlet pipes must have at least the same clearance as the safety valve. Safety valve is placed high enough to secure dripping water drain by gravity. We recommend that safety valve is mounted on a branch. This allows easier exchange without having to drain the water from the heater. Safety valves with fixed pressure settings from the manufacturer are used for the assembly. Starting pressure of a safety valve must be identical to the maximum allowed heater pressure, and at least 20 % higher than the maximum pressure in the water main (Table 2). If the water main pressure exceeds that value, reduction valve must be added to the system. **No closing armature may be mounted between the tank and the safety valve.**

During assembly, follow the guide provided by the safety equipment manufacturer.



It is necessary to check the safety valve each time before putting it into operation. It is checked by manual moving of the membrane from the seat, turning the make-and-break device button always in the direction of the arrow. After being turned, the button must click back into a notch. Proper function of the make-and-break device results in water draining through the safety valve outlet pipe. In common operation, such a check needs to be implemented at least once a month, and after each heater shutdown for more than 5 days. Water may be dripping off the drain pipe of the safety valve; the pipe must be open into the air, pointed down; environment temperatures must not drop below zero. When draining the tank, use the recommended drain valve. First of all, close water inlet in the tank.

Find necessary pressure values in the below Table 2. For proper safety valve operation, a backflow valve shall be mounted on the inlet pipes, preventing spontaneous heater draining of the tank and hot water penetration back into the water main. We recommend that the hot water distribution from the heater was as short as possible to minimise heat losses. At least one demountable joint must be mounted between the tank and every supply pipe.

Adequate piping and fittings with sufficiently dimensioned maximum temperature and pressure values must be used.

Tanks must be provided with discharge valve mounted on the cold sanitary water inlet to the tank for potential disassembly or repair.

When assembling the security equipment, follow the standard.

SAFETY VALVE START-UP PRESSURE [MPa]	ALLOWABLE OPERATING OVERPRESSURE OF WATER HEATER [MPa]	MAXIMUM PRESSURE IN COLD WATER PIPES [MPa]
0,6	0,6	up to 0.48
0,7	0,7	up to 0.56
1	1	up to 0.8

Table 2

2.4 PRESSURE LOSSES

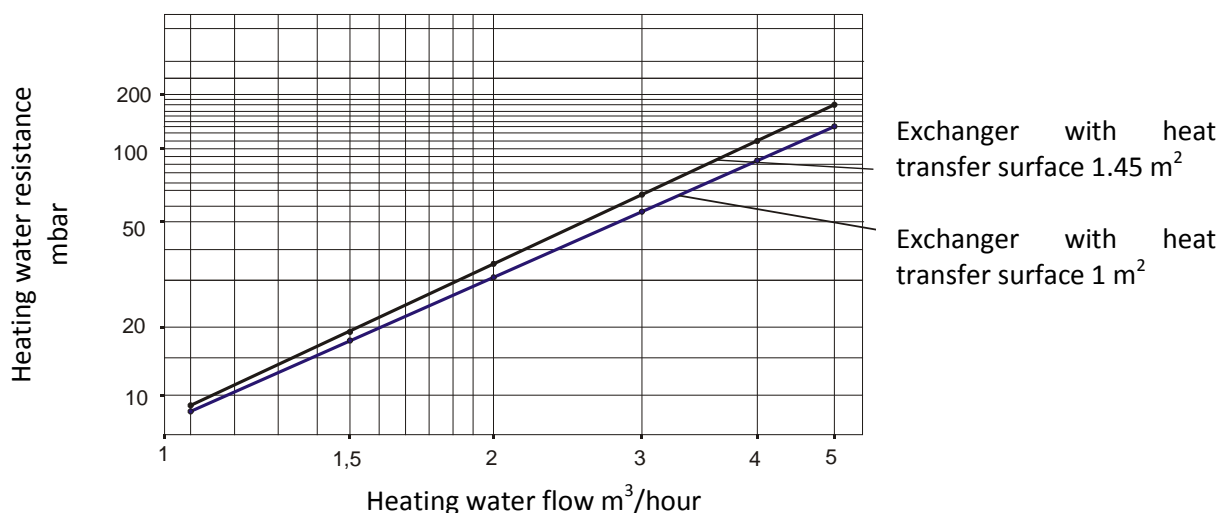

Type	Pressure loss mbar				
	tHV = 60 °C				
	Amount of heating water m3/h				
	1	2	3	4	5
Exchanger 1m2	7	24	51	86	130
Exchanger 1.45m2	9	32	68	115	174

2.5 CONNECTION OF INDIRECT TANK TO HOT WATER SYSTEM

a) *Water heating by electric energy*

When the tank is connected to power supply, the heating element heats water. The element is turned on and off by a thermostat. After reaching the temperature set, the thermostat switches off the electric circuit and thus discontinues water heating. The control light signals if the element is in operation (light is on) or if it is off (the light goes out). In case of longer operation without using the heated volume, the thermostat has to be set to position 5°C to 8°C (set the “snowflake” symbol on the thermostat selector) to avoid its freezing, or electricity supply to the heater has to be switched off. In combined tanks, the stop valve on the inlet to the exchanger has to be closed at the inlet to the heat exchanger which prevents heating the water in the hot water heating system.

b) ***Service water heating via thermal energy through heat exchanger***

Closing valves of the heat exchanger must be opened which ensures heating water flow from the hot water heating system. Together with the closing valve, it is recommended to install an air outlet valve at the inlet to the heat exchanger in order to bleed the heat exchanger as needed, in particular before the beginning of the heating season (Figure 4). The time it takes to heat up using the heat exchanger depends on the temperature and flow of water in the hot water heating system. A combined heater is made in universal design – depending on the need of connecting the closing valves to the heating element either from the right, or from the left.



It is recommended that heating water inlet and outlet are provided with shutoff valves (in case the tank has to be demounted). The valves have to be as close to the heater as possible to avoid higher thermal losses.

2.6 EXAMPLES OF TANKS CONNECTION

Connecting a tank to heating system

The tank is placed on the floor next to the heating source or in its proximity. The heating circuit shall be connected to marked tank exchanger inputs and outputs, and bleeder valve installed at the highest point. It is necessary to install a filter into the circuit in order to protect pumps, three-way valve, backflow flaps and the exchanger from sedimentation. It is recommended to flush the heating circuit before the assembly. All wiring connections must be properly insulated from heat.

If the system works with priority heating of HSW using a three-way valve, always follow the installation instructions of the three-way valve's manufacturer.

Connecting a tank to HSW system

Cold water shall be connected to an inlet marked with a blue ring and writing "HSW INLET". Hot water is connected to outlet marked with red circle or inscription "HSW OUTLET". If the hot sanitary water (HSW) distribution is equipped with circulation circuit, it shall be connected to the outlet marked with "CIRCULATION". For potential drain of heater, the HSW inlet has to be provided with a "T" fixture with a drain valve. Each individually lockable tank must be on the cold water inlet provided with a stop gate, test tap, safety valve with a reverse flap and a pressure gauge.

Example of group connection of tanks by Tichellman method for equal HSW withdrawal of from all tanks

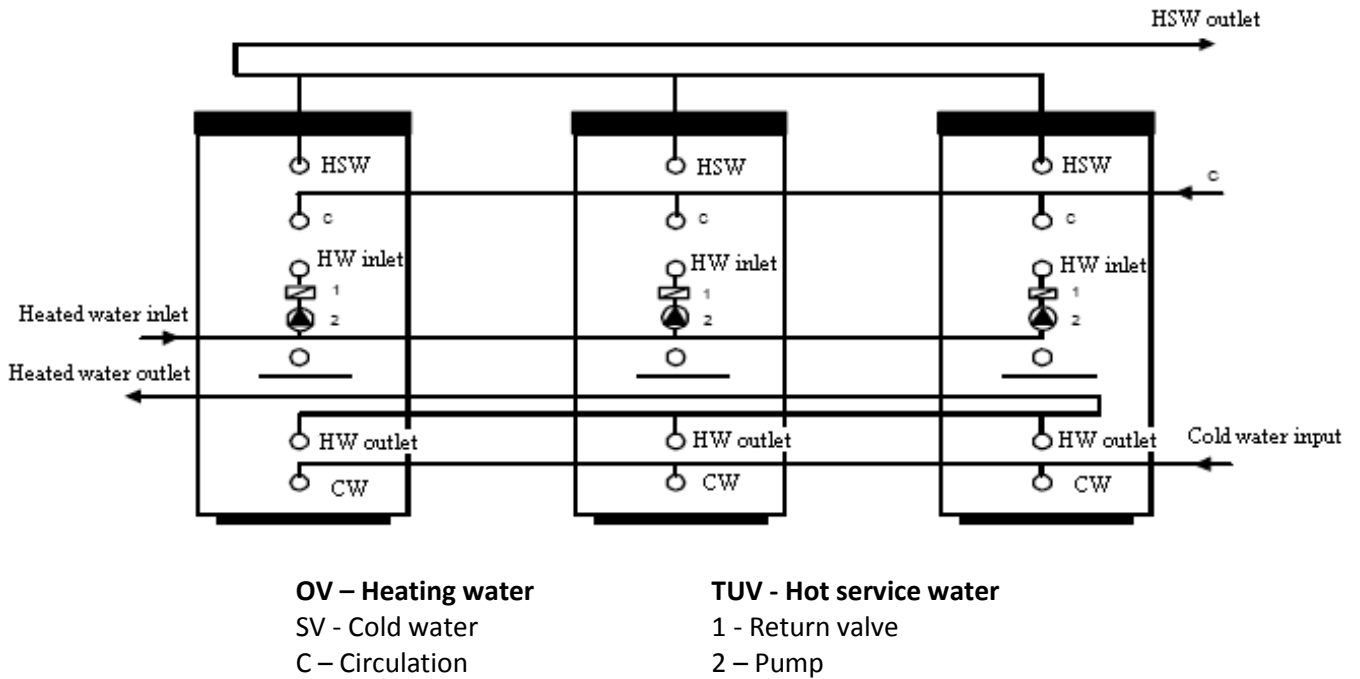
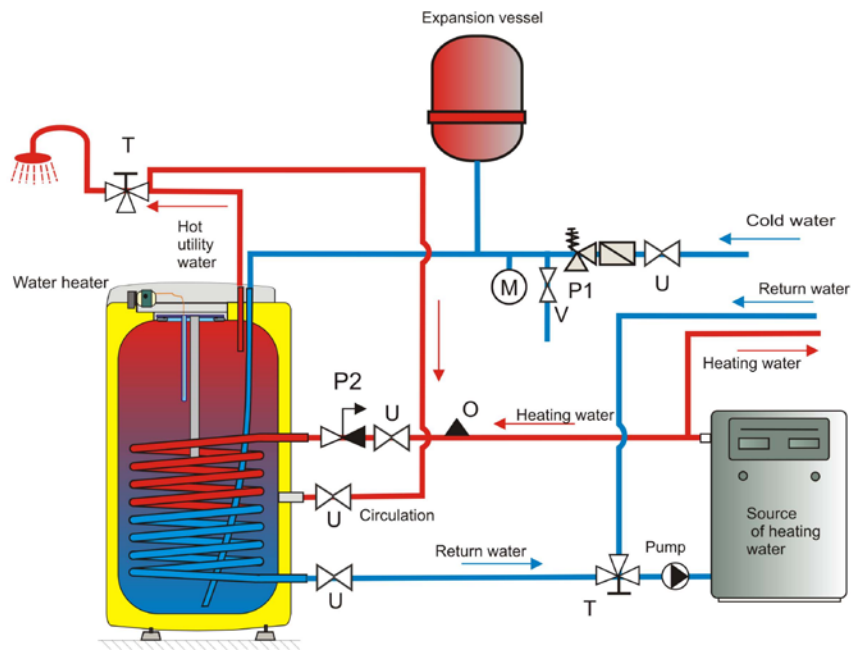

Figure 3



- U - Shut-off valve
- P1 - Pressure relief valve with backflow valve
- P2 - Pressure relief valve for rating circuit
- V - Drain valve
- M - Manometer
- T - Three-way valve
- O - Bleeder valve

Figure 4

* Use of an expansion vessel is not a condition correct connection only an alternative solution.

2.7 FIRST COMMISSIONING

Once the tank is connected to water supply system and power supply, and safety valve tested (accordingly with the manual attached to the valve), the heater can be put in operation.

Procedure:

- a) check the water main and wiring; Check proper placement of thermostat sensors. The sensors in the well must be inserted all the way in; first the operating and then the safety thermostat.
- b) open the hot water valve on the combination faucet;
- c) open the cold water inlet valve to the tank;
- d) once water starts draining through the hot water valve, filling of the tank is completed and the valve must be closed;
- e) if a flange lid leak is discovered, the flange lid bolts need to be tightened;
- f) fasten the electric installation cover;
- g) when hot sanitary water is heated by **electric energy**, switch on the power supply (the valve on the heating water inlet to the heating insert must be closed in combined tanks).
- h) when sanitary water is heated with **electric energy** from hot water heating system, turn off electricity and open the valves on the heating water inlet and outlet, possibly de-aerate the exchanger.
- i) once the operation restarts, keep flushing the tank until the cloud disappears;
- j) make sure to fill in properly the warranty certificate.

2.8 CLEANING OF TANK AND EXCHANGE OF ANODE ROD

Repetitive water heating causes limestone sediment on both the enamelled tank walls and chiefly the flange lid. Lime scale settling depends on hardness of heated water, its temperature and on the volume of hot water used.



We recommend checking and cleaning the tank from scale and eventual replacement of the anode rod after two years of operation.

The anode life is theoretically calculated for two years of operation; however, it changes with water hardness and chemical composition in the place of use. Based on such an inspection, the next term of anode rod exchange may be determined. Have a company in charge of service affairs deal with the cleaning and exchanging of the anode. When draining water from the tank, the combination faucet valve for hot water must be open, preventing the occurrence of under-pressure in the tank receptacle which would stop water from draining.



To prevent the occurrence of bacteria (e.g. *Legionella pneumophila*) within stack heating it is recommended, if absolutely necessary, to increase the temperature of hot service water (HSW) periodically for a transitional period of time to at least 70°C. It is also possible to make use of another way of disinfecting HSW.

2.9 SPARE PARTS

- flange lid
- thermostat and thermal fuse
- control lights with wires
- heating element
- flange lid seal
- magnesium anode
- temperature indicator
- insulation flange lid
- control button for the thermostat
- set of M12 (or M10) bolts

When ordering spare parts, give part name, type, and type number from the heater label.

3 OPERATION OF THERMOSTAT

3.1 SERVICING

3.1.1 OPERATING DEVICES OF THE HEATER

The service devices of 100 and 125 litre tanks are located under the plastic guard of the control panel (Figure 5).

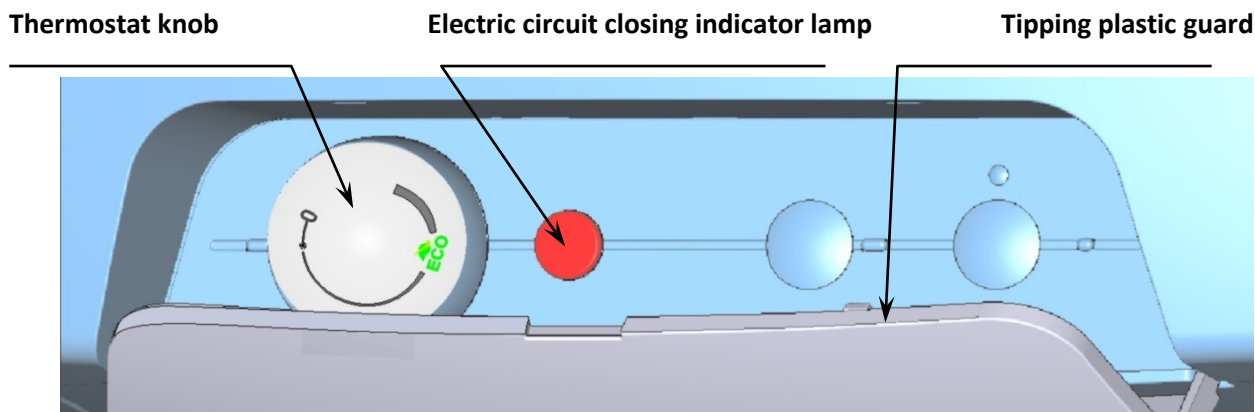

Figure 5

3.1.2 TEMPERATURE SETTING

Water temperature is set by turning the thermostat knob. The desired symbol is adjusted against the fixed point on the control panel (Figure 6).

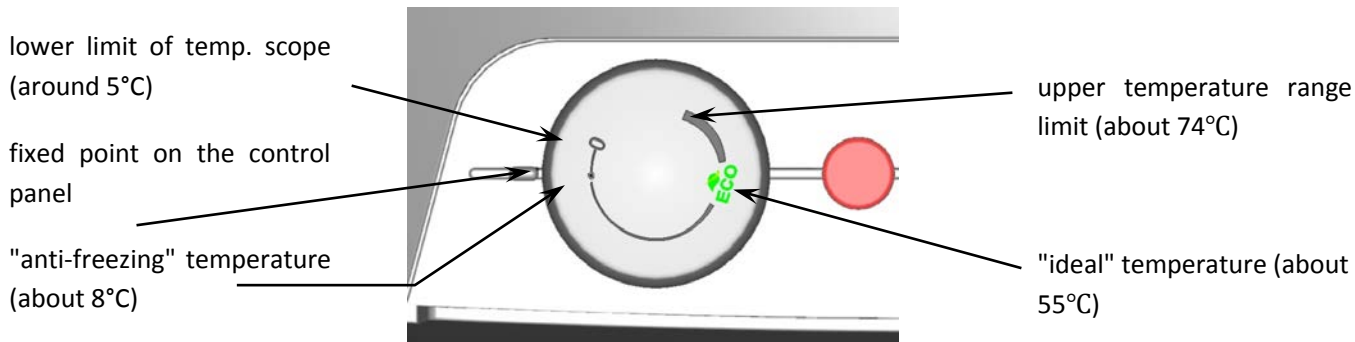

Figure 6



Adjusting the thermostat knob to the left backstop does not mean permanent shutoff of the heating element. When the heater is in use without blocking the daily rate, we do not recommend the temperature to be set above 65°C. Select the "ECO" symbol as the maximum.

3.2 MOST FREQUENT FUNCTION FAILURES AND THEIR CAUSES

FAILURE SYMPTOM	INDICATOR	SOLUTION
Water is cold	<ul style="list-style-type: none"> Light on 	<ul style="list-style-type: none"> Heating element failure
Water is not warm enough	<ul style="list-style-type: none"> Light on 	<ul style="list-style-type: none"> failure of one of the heating coils in the element
Water is cold	<ul style="list-style-type: none"> Light off 	<ul style="list-style-type: none"> Thermostat failure The safety thermostat shut off the power supply. Electric supply outside the heater interrupted
Temperature of water is not corresponding with the temperature set on the control	<ul style="list-style-type: none"> Light on 	<ul style="list-style-type: none"> Thermostat failure

Table 3



Do not attempt to repair the failure yourselves. Seek either expert or service help. It does not take much for an expert to remove the defect. When organizing repair state the model designation and serial number that is to be found on the power plate of your water tank.

4 IMPORTANT NOTICES

4.1 INSTALLATION REGULATIONS



Without a proof issued by a professional company about performed electrical and plumbing fixture the warranty shall be void.

It is necessary to check the protective magnesium anode periodically and replace it if necessary.

No closing armature may be mounted between the tank and the safety valve.

If the overpressure in the eater main exceeds 0.48 MPa, a reduction valve must be mounted before the safety valve.

All outlets of hot water must be equipped with combination faucets.

Before the first filling of water heater it is recommended to tighten the nuts of the flange joint of the tank.

It is not allowed to handle the thermostat, aside from temperature resetting with a control button.

All electric installation handling, setting, and regulation feature exchange, may only be implemented by a service company.

The thermal fuse must not be turned off! In case of a thermostat defect, the thermal fuse interrupts electric power supply to the heating element if the water temperature in the heater exceeds 95°C.

As an exception, the thermal fuse may also switch off due to water overheating caused by overheating the hot water heating system boiler (in case of a combined heater).

We recommend that the tank is only operated on one energy source.



Both the electric and water installation must follow and meet the requirements and regulations relevant in the country of use!

4.2 DISPOSAL OF PACKAGING MATERIAL AND NON-FUNCTIONING PRODUCT

A service fee for providing return and recovery of packaging material has been paid for the packaging in which the product was delivered. The service fee was paid pursuant to Act No 477/2001 Coll., as amended, at EKO-KOM a.s. The client number of the company is F06020274. Take the water boiler packages to a waste disposal place determined by the town. When the operation terminates, disassemble and transport the discarded and unserviceable heater to a waste recycling centre (collecting yard), or contact the manufacturer.



31-03-2016