

OPERATING AND INSTALLATION MANUAL

HEATING FLANGE WITH CERAMIC ELEMENTS

TPK 150 - 8 / 2,2 kW	} - 1 Thermowell
TPK 150 - 8 / 3,3 kW	
TPK 168 - 8 / 2,2 kW	
TPK 168 - 8 / 3,3 kW	
TPK 210 - 12 / 2,2 kW	
TPK 210 - 12 / 3,3 kW	
TPK 210 - 12 / 6,6 kW	
TPK 210 - 12 / 9 kW	
TPK 210 - 12 / 12 kW	



Družstevní závody Dražice - strojírna s.r.o.
Dražice 69, 294 71 Benátky nad Jizerou
Phone: +420 /326 370 911
e-mail: export@dzd.cz

 **DRAŽICE**
NIBE GROUP MEMBER

CONTENTS

1	USE.....	4
2	DESCRIPTION	4
3	FUNCTION	5
4	ADVANTAGES OF USE	5
5	ENERGY SAVING.....	5
6	OPERATION AND TEMPERATURE SETTING.....	6
7	OPERATION PRECONDITIONS	6
8	ASSEMBLY AND SAFETY INSTRUCTIONS.....	7
8.1	GENERAL INSTRUCTIONS.....	7
8.2	TPK - DIVISION	8
8.3	HEATING UNIT ASSEMBLY	10
8.4	ELECTRICAL CONNECTION	10
8.5	PUTTING INTO OPERATION	12
9	INSPECTION, CARE, MAINTENANCE	12
10	MALFUNCTIONS.....	13
11	TECHNICAL DATA	14
12	IMPORTANT NOTICES	16
12.1	SPARE PARTS LIST	16
13	DISPOSAL OF PACKAGING MATERIAL AND NON-FUNCTIONING PRODUCT.....	16

CAREFULLY READ THIS MANUAL BEFORE INSTALLING THE WATER HEATER!

Dear customer,

The Works Cooperative of Dražice - Machine Plant, Ltd., would like to thank you for your decision to use a product of our brand.



The product is not intended to be controlled by

- a) people (including children) with reduced physical, sensual or mental capacities, or
- b) people with insufficient knowledge and experiences unless supervised by responsible person, or unless properly instructed by such responsible person.

The manufacturer reserves the right to make technical changes to the product that do not affect the function and use of the product.

It is recommended to use the product in indoor environment with air temperatures from +2 °C to +45 °C and a relative humidity up to 80 %.

Product's reliability and safety is proven by tests implemented by the Engineering Test Institute in Brno.

Made in the Czech Republic.

Meaning of pictograms used in the Manual



Important information for heater users.



Abiding by the recommendations of the manufacturer serves to ensure trouble-free operation and the long service life of the product.



Caution!
Important notice to be observed

1 USE

The TPK series heating flanges are designed as main heating devices for electric heaters from DZD type OKCE S as secondary heating devices for OKC NTR(R)/BP, OKC NTR/HP, OKC NTRR/HP/SOL and accumulation tanks of heating, solar and other systems. Heating flange can be used to heat water also in other facilities provided the installation instructions are achieved. With their construction, they are only designed to heat water up to tank pressure of 1 MPa and temperature of 110 °C.



TPK cannot be used in stainless steel water heaters or stainless steel storage tanks.

2 DESCRIPTION

Heating flange is an enameled weld of flange and wells. TPK is equipped with a thermostat and a safety fuse with external control and relevant electric installation. The electric wiring is placed underneath a plastic cover.

TPK 150 - 8 / 3,3 kW – 1 thermowell

TPK 168 - 8 / 3,3 kW – 1 thermowell

TPK 150 - 8 / 2,2 kW – 1 thermowell

TPK 168 - 8 / 2,2 kW – 1 thermowell

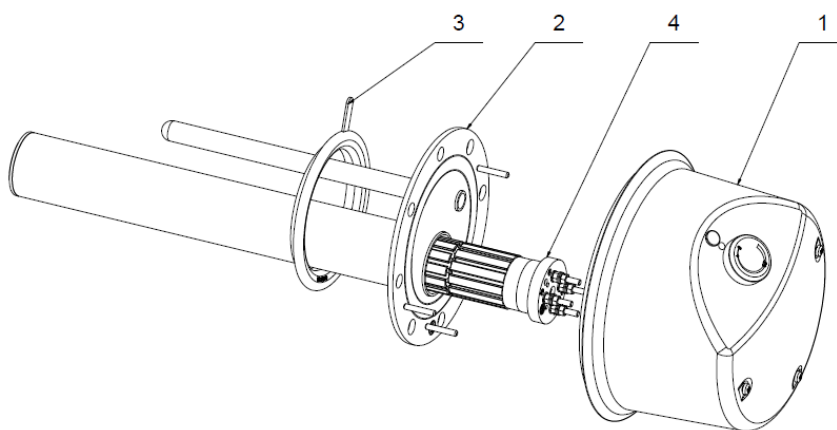

TPK 210 - 12 / 2,2 kW - 1 thermowell

TPK 210 - 12 / 3,3 kW - 1 thermowell

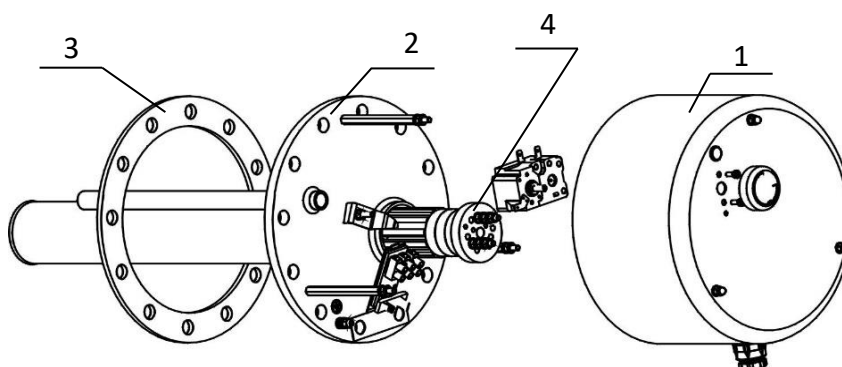

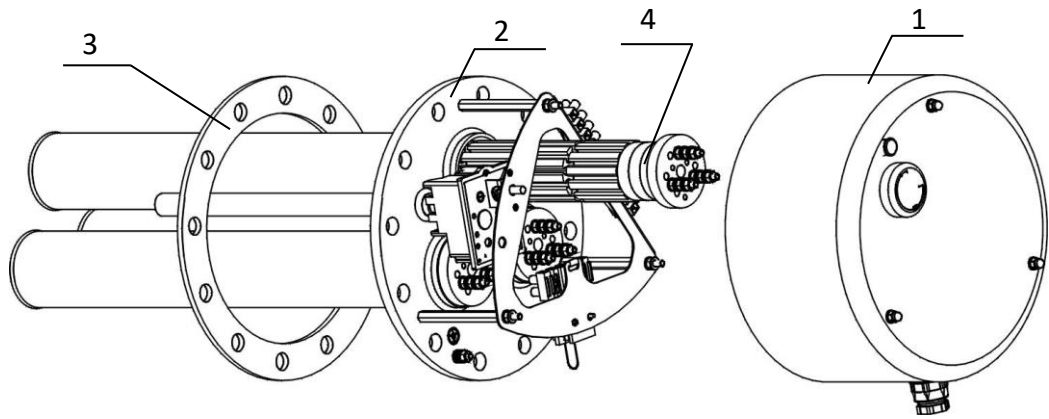

1. Plastic electric installation guard
2. Heating flange

3. Gasket
4. Ceramic element

3 FUNCTION

After setting the heating temperature between 5 °C - 74 °C, the in-built PTK is unmanned. The thermostat activates heating elements and after reaching the set temperature the thermostat turns off. The operation of the element is indicated with lit up control signal lamps (glow lamps). If the thermostat fails, the safety fuse deactivates power supply if 95 °C is reached. The safety fuse is non-reversible, i.e. that it has to be turned on once the failure is removed.

4 ADVANTAGES OF USE

- Heating flange with elements in steel wells is more resistant in waters rich in calcium, with increased formation of scale.
- Placing the elements in steel wells increases the lifetime of the heater tank. Electric potential is better kept at corresponding values.
- If the element fails, it can be replaced without draining water from the tank.
- In addition to the TPK 210-12/9 kW and TPK 210-12/12 kW, an asymmetric load of the phases is also possible, e.g. for the processing of PV power surpluses.

5 ENERGY SAVING

Low water temperature in the heater proves to be especially economic. Therefore, the temperature should be set to be adequate for intended hot water consumption, not higher. This helps to save electricity and prevents lime sediment occurrence.

6 OPERATION AND TEMPERATURE SETTING

The temperature of water in the heater can be adjusted as needed by the thermostat, either continuously or in three steps as indicated. This allows energetically economic operation. To set the temperature, 3 main marked symbols are used:

- * accumulator freezing protection
- Approx. **60 °C**, hot water - to prevent scalding, setting this degree is recommended as it is the economic operation with minimum energy loss and minimum scale occurrence
- maximum, approx. **74 °C**, hot water

Attention: If the thermostat controller is turned to the leftmost position (control stop), it is not the 0 °C position, nor is it the off position!

During day mode operation, the thermostat should not be set to temperatures above 60 °C.

7 OPERATION PRECONDITIONS

The connection of an electric flange unit must follow the data on the plate (operation pressure, electrical parametr). **Connecting to the electrics must follow the scheme on the inside of the protective cover for the particular flange types.**

Aside from the electric regulations the conditions of local distribution and water supply plants, as well as assembly and operation conditions, must be followed. If the water is really hard, we recommend installation of water treatment filters preventing the scale occurrence.

These heating elements are suitable for enameled accumulators, double casing tanks, or accumulators coated with either plastic or zinc; they are also suitable for ribbed exchangers. Combination with chromium-nickel tanks is problematic, and therefore not recommended. All elements are suitable for heating drinkable and heating water with operating pressure within 10 bar.

8 ASSEMBLY AND SAFETY INSTRUCTIONS

8.1 GENERAL INSTRUCTIONS

During operation, both the heating element and the anode rod must be under water. Necessary thermal flow of heated water must not be prevented. The heating unit is equipped with a safety fuse preventing further water heating at the maximum temperature of 95 °C approximately. It is therefore necessary to select suitable connecting components (pipelines, safety valve combination) that, in case of thermostat defect, resist the maximum temperature of 110 °C.

Both the assembly and installation must be implemented by authorized people only.

Position of installation of TPK series elements

Correct

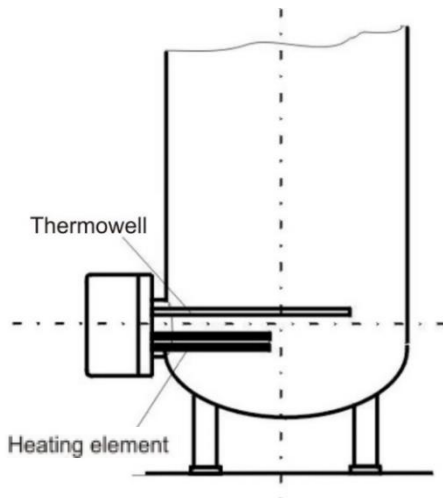

Faulty

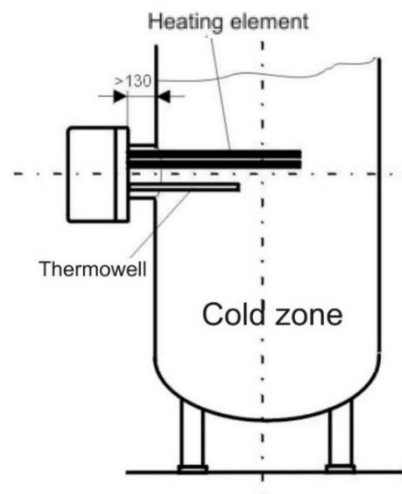

Too long flange welded too high.
Thermowell under the heating element.

The flange rim must not exceed 130 mm, so that the temperature sensor and the element reach into the tank deep enough. Correct position of a built-in element assures even heating of the tank contents. In front of the flange, a free space depending on the length of the element must be left for the assembly. Scale occurrence lowers functionality; it is therefore necessary, especially with hard water, to take the following measures: Select proper temperature setting; install a device reducing water hardness; regular removal of heater scale.

8.2 TPK - DIVISION

TPK 150 - 8 / 2,2 kW – 1 thermowell

TPK 150 - 8 / 3,3 kW – 1 thermowell

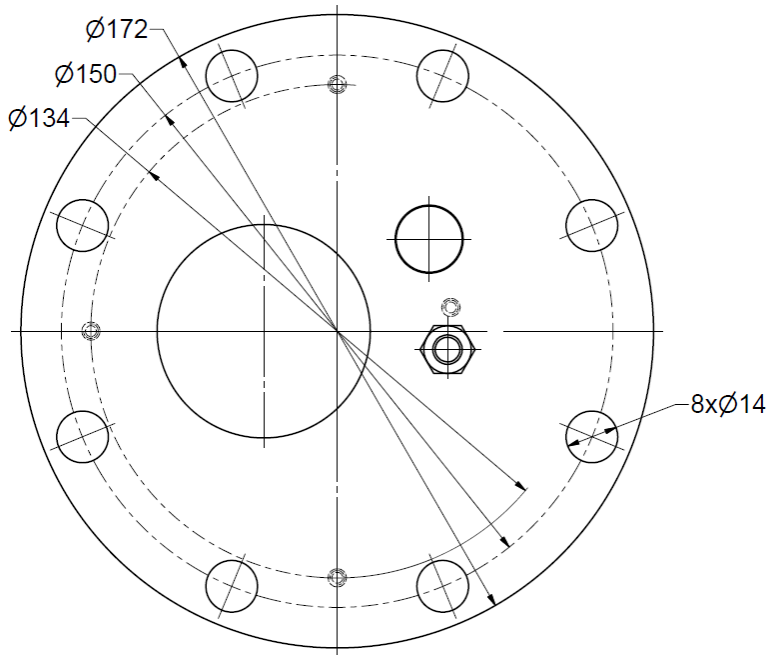

Example of use:

OKC 300 NTR/HP

OKC 500 NTR/HP

OKC 400 NTRR/HP/SOL

OKC 500 NTRR/HP/SOL

TPK 168 - 8 / 2,2 kW – 1 thermowell

TPK 168 - 8 / 3,3 kW – 1 thermowell

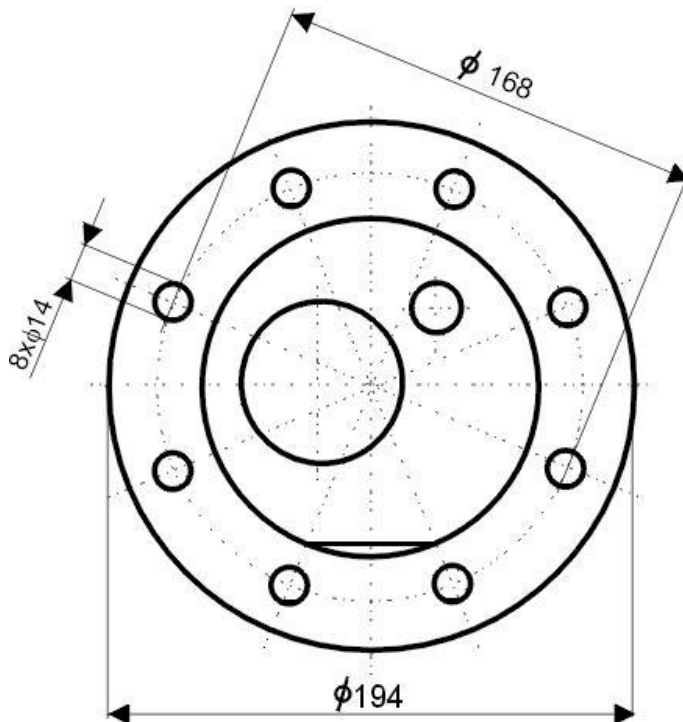

Example of use:

OKC 160 NTR/BP

OKC 200 NTR(R)/BP

TPK 210 - 12 / 2,2 kW - 1 Thermowell
 TPK 210 - 12 / 3,3 kW - 1 Thermowell

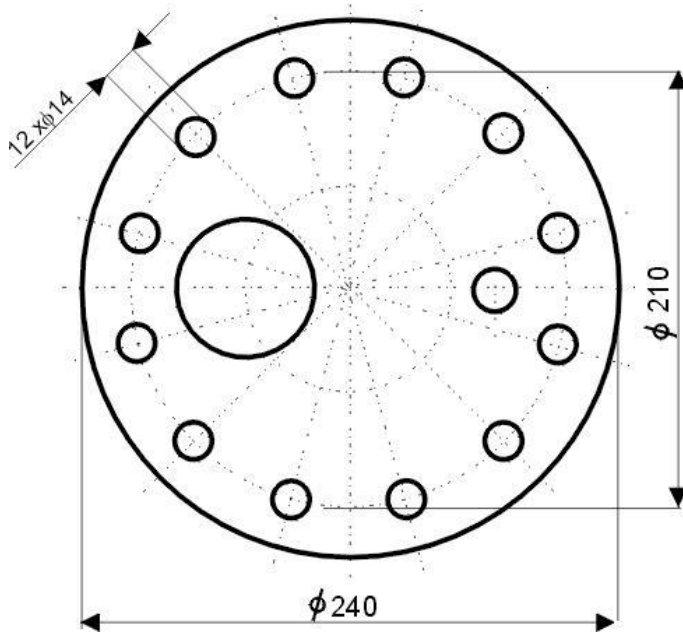

Example of use:

OKCE 160 S
 OKCE 200 S
 OKCE 250 S
 OKCE 300 S
 OKCE 500 S

OKC 300 NTR(R)/BP
 OKC 500 NTR(R)/BP

Tanks NAD and NADO with
 flange 210 mm.

TPK 210 - 12 / 6,6 kW
 TPK 210 - 12 / 9 kW
 TPK 210 - 12 / 12 kW

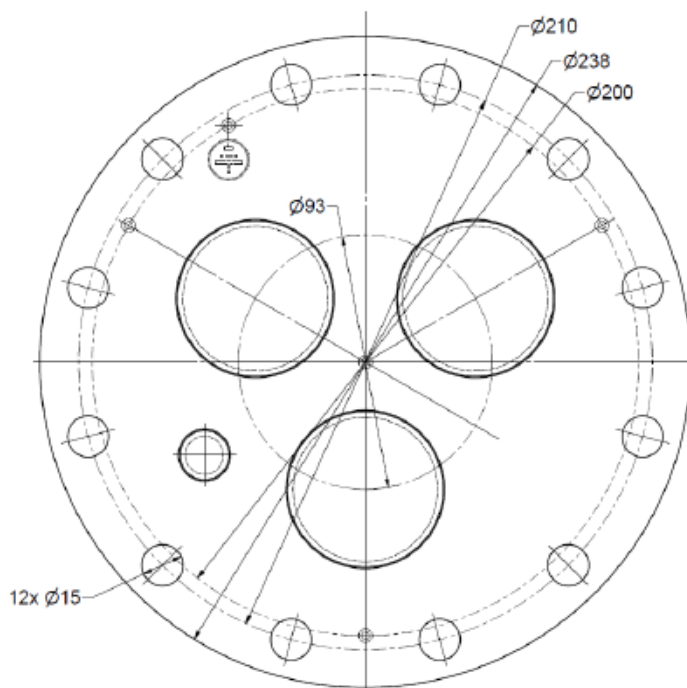

Example of use:

OKCE 160 S *
 OKCE 200 S *
 OKCE 250 S *
 OKCE 300 S
 OKCE 500 S

OKC 300 NTR(R)/BP *
 OKC 500 NTR(R)/BP *

Tanks NAD and NADO with
 flange 210 mm.

* - TPK 210-12/9 kW and TPK 210-12/12 kW can't be mounted.

8.3 HEATING UNIT ASSEMBLY

Aside from the installation regulations, the conditions of connection resulting from local distribution and water supply plants must be followed:

1. Remove protective cover (position 1)
2. For the TPK 150-8 and TPK 168-8 variants, fit the gasket, store the heating flange (position 2) and screw the screws into the flange on the tank (tightening torque 15 Nm). For the TPK 210-12 variants, screw 3 M12x50 auxiliary threaded rods evenly around the perimeter into the 3 threaded holes on the flange. Place the gasket on them and store the heating flange (position 2). Then screw in the remaining 9 M12x30 screws and tighten in a cross pattern (tightening torque 15 Nm). Then unscrew the threaded rods and replace them with the remaining 3 screws M12x30 and tighten (tightening torque 15 Nm).
3. Carry out electric connection following the scheme (see point 8.5). Warning - do not forget to connect the guard wire. With flanges with selectable output, interconnect the terminal boards to the required output.
4. Put on the protective guard and thermostat control. Cover the gap between the heater shell and flange guard with the attached profile.
5. Commissioning is possible solely when the tank is filled with water.

Heating element assembly and its initial operation can only be implemented by an expert, who takes responsibility for proper implementation and equipment.

The space in front of the electrical heating unit equal to the installation length + 50 mm must be left free for installation, etc.

8.4 ELECTRICAL CONNECTION

The electrical connection must be implemented based on the attached scheme. The scheme is placed inside the plastic cover of the heating flange, and it relates to the specific type!



The network voltage must be respected!

All metal parts of the accumulator must meet relevant protective regulations.

Notice: Perform the installation in compliance with applicable CSN standards.

All switches must be connected to circuit breakers. The supply cable must be supplied into the area of connection via a sealing bushing and secured from shifting, wringing, and tearing out by a clamp.

Wiring scheme Heating unit 2,2 kW



Caution! The factory connection must not be changed!

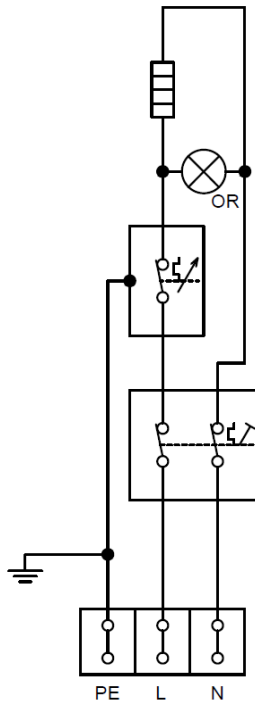

Heating unit 3,3 kW and 6,6 kW



Caution! The factory connection must not be changed!

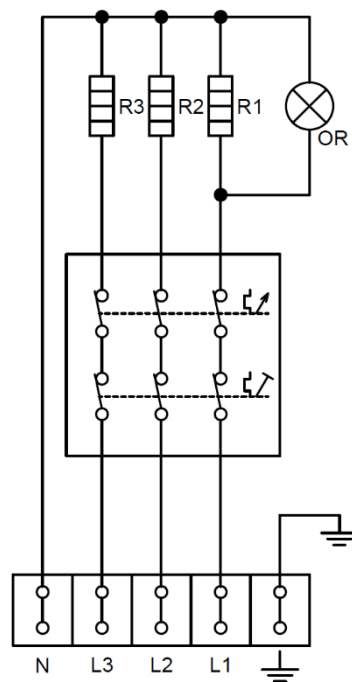

Heating unit 9 kW and 12 kW



Caution! The factory connection must not be changed!

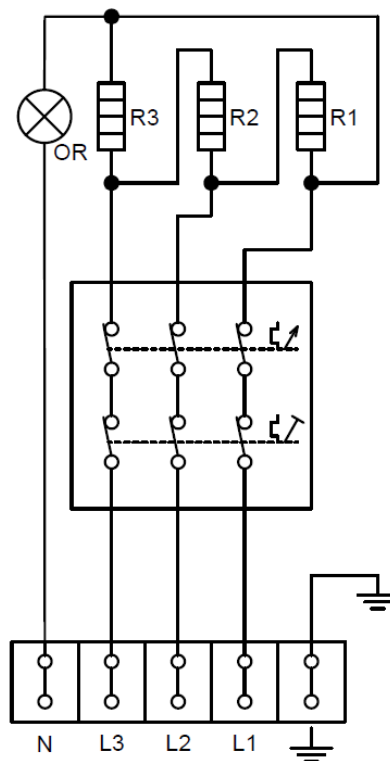

8.5 PUTTING INTO OPERATION

Before electric part connection, the accumulator must be filled with water. During the rating, water must drip off the safety valve.

Attention: Both the hot water outlet pipe and safety armature parts may be hot.

After heating, the set temperature of consumed water should roughly correspond with temperature shown on the thermometer.

9 INSPECTION, CARE, MAINTENANCE

High calcium content water requires the removal of both scale and calcium sediments after one or two years, implemented by an expert worker. Cleaning may be implemented through the flange opening; a new seal must be used during assembly.

Specially enameled accumulator containers must not get in contact with scale solvents or a lime pump. Eventually, the container must be thoroughly rinsed; its re-heating must follow the method of initial operation.

During the maintenance, protective connection of all metal (conductive) parts of the heater must not be damaged or removed. Neither mechanical means causing abrasion nor paint thinners (nitro, tricholor, etc.) can be used for cleaning. It is best to use a wet cloth with couple drops of a neutral cleaning preparation.

10 MALFUNCTIONS

Do not attempt to repair the failure yourselves. Seek either expert or service help. It does not take much for an expert to remove the defect. When making a repair appointment, report the type and serial number you find on the performance plate of your heating element.

Defect		Failure	
1	Water in the tank is cold	LED is on	- heating element failure - some elements are not heating
2	Water in the tank is not warm enough	LED is on	- failure of one of the elements - failure of one of the heating coils in the element, see note
3	Water in the tank is cold	LED is not on	- thermostat failure - the safety fuse turned off electricity supply - power supply outside the heater discontinued
4	Water in the tank does not correspond with temperature set	LED is on	- thermostat failure

After checking and correcting the cause of the failure of the temperature control in the no-voltage state and cooling the water to room temperature, it is possible to manually switch the fuse on by pressing the lock!

11 TECHNICAL DATA

Screw spacing circle diameter 150 mm: TPK 150 - 8 / 2,2 kW – 1 thermowell

TPK 150 - 8 / 3,3 kW – 1 thermowell

Screw spacing circle diameter 168 mm: TPK 168 - 8 / 2,2 kW – 1 thermowell

TPK 168 - 8 / 3,3 kW – 1 thermowell

Screw spacing circle diameter 210 mm: TPK 210 - 12 / 2,2 kW – 1 thermowell

TPK 210 - 12 / 3,3 kW – 1 thermowell

TPK 210 - 12 / 6,6 kW; TPK 210 - 12 / 9 kW

TPK 210 - 12 / 12 kW

Range of thermostat settings: Continuous setting from 5 °C by approx. 74 °C. The gasket is attached.

Type	Output [kW]	Connection	Recommended breaker [A]	Build-up length [mm]
TPK 150 - 8 / 2,2 kW - 1 thermowell	2,2	1 PE - N AC 230 V / 50 Hz	16	400
TPK 150 - 8 / 3,3 kW - 1 thermowell	3,3	3 PE - N AC 3x 230 V / 50 Hz	3x 10	400
TPK 168 - 8 / 2,2 kW - 1 thermowell	2,2	1 PE - N AC 230 V / 50 Hz	16	400
TPK 168 - 8 / 3,3 kW - 1 thermowell	3,3	3 PE - N AC 3x 230 V / 50 Hz	3x 10	400
TPK 210 - 12 / 2,2 kW - 1 thermowell	2,2	1 PE - N AC 230 V / 50 Hz	16	470
TPK 210 - 12 / 3,3 kW - 1 thermowell	3,3	3 PE - N AC 3x 230 V / 50 Hz	3x 10	470
TPK 210 - 12 / 6,6 kW	6,6	3 PE - N AC 3x 230 V / 50 Hz	3x 16	440
TPK 210 - 12 / 9 kW	9	3 PE - N AC 400 V / 50 Hz	3x 20	550
TPK 210 - 12 / 12 kW	12	3 PE - N AC 400 V / 50 Hz	3x 25	550

Time of heating the heating flange in hours:

	TPK 150 - 8 / 2.2 kW	TPK 150 - 8 / 3.3 kW 1 thermowell	TPK 168 - 8 / 2.2 kW	TPK 168 - 8 / 3.3 kW 1 thermowell	TPK 210 - 12 / 2.2 kW1 thermowell	TPK 210 - 12 / 3.3 kW1 thermowell	TPK 210 - 12 / 6.6 kW	TPK 210 - 12 / 9 kW	TPK 210 - 12 / 12 kW
OKCE 160 S	-	-	-	-	4,25	2,75	1,5	-	-
OKCE 200 S	-	-	-	-	5,5	3,75	2	-	-
OKCE 250 S	-	-	-	-	6,75	4,5	2,25	-	-
OKCE 300 S	-	-	-	-	8	5,25	2,75	2	1,5
OKCE 500 S	-	-	-	-	12,5	8,25	4	3	2,25
OKC 160 NTR/BP	-	-	4	2,75	-	-	-	-	-
OKC 200 NTR/BP	-	-	5,5	3,75	-	-	-	-	-
OKC 200 NTRR/BP	-	-	5,25	3,5	-	-	-	-	-
OKC 300 NTR/BP	-	-	-	-	8	5,25	2,75	-	-
OKC 300 NTRR/BP	-	-	-	-	7,75	5	2,5	-	-
OKC 500 NTR/BP	-	-	-	-	12	8	4	-	-
OKC 500 NTRR/BP	-	-	-	-	11,5	7,75	4	-	-
OKC 200 NTR/HP	-	-	5,5	3,75	-	-	-	-	-
OKC 250 NTR/HP	-	-	6,25	4,5	-	-	-	-	-
OKC 300 NTR/HP	7,75	5	-	-	-	-	-	-	-
OKC 500 NTR/HP	12,5	8,25	-	-	-	-	-	-	-
OKC 400 NTRR/HP/SOL	9,5	6,25	-	-	-	-	-	-	-
OKC 500 NTRR/HP/SOL	12,5	8,25	-	-	-	-	-	-	-

12 IMPORTANT NOTICES



The following cases do not entitle the Customer to exercise the right from defective performance:

- damage caused by dry operation
- damage caused by lime scale deposits
- damage caused by chemical or electrochemical influences
- damage due to incorrect voltage, lightning strike, or voltage surges
- any tampering with the product that alters or disrupts the original certified electrical wiring inside the product
- any modifications made by the installation technician/customer are at his/her own risk and responsibility!

12.1 SPARE PARTS LIST

- Housing cover
- Gasket
- Ceramic element 2.2 kW for single-phase connection
- Ceramic element 1.1 kW; 2.2 kW; 3 kW; 4 kW for three-phase connection
- Thermostat, Safety fuse, Combined thermostat
- Wire set
- Thermostat controller
- Set of bolts

More on <https://www.dzd.cz/en>

13 DISPOSAL OF PACKAGING MATERIAL AND NON-FUNCTIONING PRODUCT

A service fee for providing return and recovery of packaging material has been paid for the packaging in which the product was delivered. The service fee was paid pursuant to Act No 477/2001 Coll., as amended, at EKO-KOM a.s. The client number of the company is F06020274. Take the water tank packages to a waste disposal place determined by the municipality. When the operation terminates, disassemble, and transport the discarded and unserviceable heater to a waste recycling center (collecting yard), or contact the manufacturer.



9-10-2024