

OPERATING AND INSTALLATION MANUAL

STORAGE TANKS

NADS 800 v3

NADOS 800/140 v1

NADOS 800/140 v2

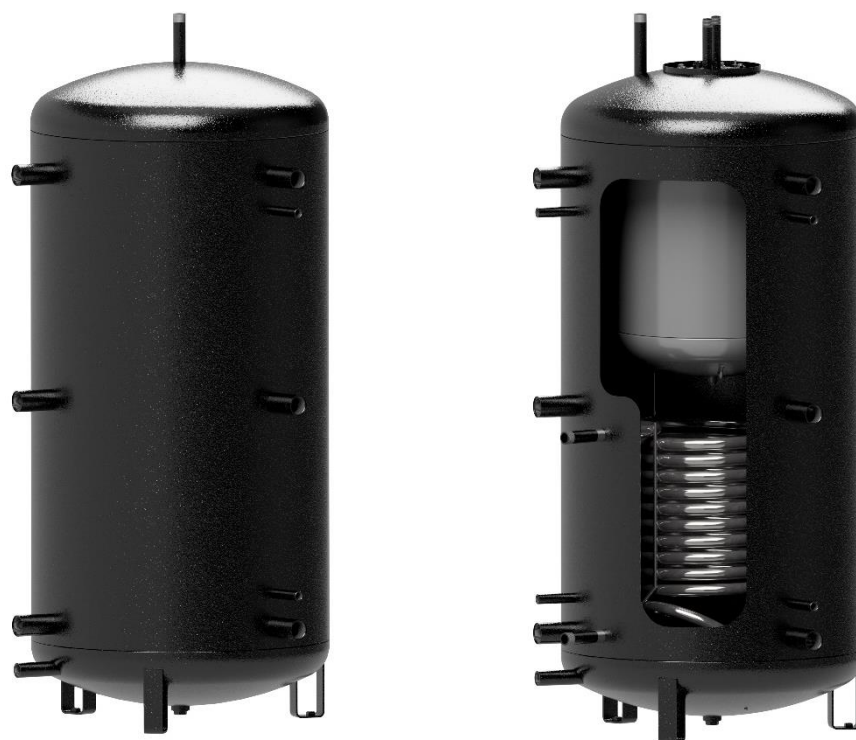

Družstevní závody Dražice-strojírna s.r.o.
Dražice 69, 294 71 Benátky nad Jizerou
tel.: +420 / 326 370 911
e-mail: export@dzd.cz

 **DRAŽICE**
NIBE GROUP MEMBER

CONTENTS

1	DESCRIPTION	4
2	DESIGNING THE SIZE AND CONNECTION OF STORAGE TANK	4
3	TECHNICAL PARAMETERS	5
4	IMPORTANT NOTICES	6
5	TECHNICAL DESCRIPTION	7
6	DIMENSIONS AND CONNECTION	8
7	DISPOSAL OF PACKAGING MATERIAL AND NON-FUNCTIONING PRODUCT.....	11

CAREFULLY READ THIS MANUAL BEFORE INSTALLING THE TANK!

Dear Customer,

Družstevní závody Dražice - strojírna s.r.o., would like to thank you for your decision to use a product of our brand.



The product is not intended to be controlled by

- a) people (including children) with reduced physical, sensual or mental capacities, or
- b) people with insufficient knowledge and experiences unless supervised by responsible person, or unless properly instructed by such responsible person.

The manufacturer reserves the right for engineering modification of the product.

It is recommended to use the product in indoor environment with air temperatures from +2 °C to +45 °C and a relative humidity up to 80 %.

Product's reliability and safety is proven by tests implemented by the Engineering Test Institute in Brno.

Made in the Czech Republic.

Meaning of pictograms used in the Manual



Important information for heater users.



Abiding by the recommendations of the manufacturer serves to ensure trouble-free operation and the long service life of the product.



Caution!
Important notice to be observed.

1 DESCRIPTION

Storage tanks are used to accumulate excess heat from its source. The source can be a solid fuel boiler, heat pump, solar collectors, fireplace insert, etc.

The NADS tanks only serve to store heat in a heating system. The NADOS tanks also allow heating or preheating of DHW in the inner vessel. The integration of the storage tank into a heating system with the solid fuel boiler enables optimal operation of the boiler at a favorable temperature during the operation of the boiler. The benefit is mainly the period of the optimal operation (i.e. with maximum efficiency) when the excess heat is stored in the tank.

The tanks as well as the possible tube exchangers are made of steel, without any treatment of the inner surface; the outer surface of the tank is provided with a protective coating. The tanks are made in volumes of 800 liters. The particular versions are also equipped with a tube heat exchanger, each with an area 1.5 m².

The NADOS type allows direct heating of the domestic hot water (DHW) in an inner enameled vessel, or its preheating or another water heater. The connection with the boiler usually allows direct heating of DHW in the inner tank to the required temperature, while the connection to solar collectors or a heat pump only preheats the DHW and it is necessary to include another, e.g. electric heater, which heats the water to the required temperature, or to install an electric heater into the storage tank, which can be an electrical heating unit TJ 6/4". The storage tanks are equipped with a removable 80 mm thick insulation and a lock.

The tanks are not intended for storing DHW - domestic hot water.

2 DESIGNING THE SIZE AND CONNECTION OF STORAGE TANK

An ideal size of the storage tank is designed by a design engineer, or a person sufficiently qualified to design heating systems.

Product assembly must be implemented by an authorized person (confirmed in the warranty certificate).

When putting into operation, water has to be filled first into the inner tank for HSW and the operating pressure inside it has to be kept, only then heating water can be filled into the outer storage tank, otherwise the product may get damaged!



The manufacturer explicitly emphasizes the necessity of being particular in testing the tightness of the heating circuit (radiators, piping joints, floor heating, etc.) with the connection of the storage tank. No pressure grow in the storage tank heating water compartment may occur above the maximum operating pressure of 0.3 MPa, if the heating system is pressurized to higher than the maximum operating pressure, the inner enameled tank may get permanently damaged!



Before assembly, we recommend rinsing the container and the heating circuit with clean water!

3 TECHNICAL PARAMETERS

TYPE	NADOS 800/140v1	
	NADOS 800/140v2	
TANK VOLUME	l	775
TANK VOLUME FOR HOT WATER HEATIG	l	140
WEIGHT WITHOUT INSULATION	kg	128 155
MAXIMUM PRESSURE IN THE TANK	bar	3
MAXIMUM PRESSURE IN THE HOT WATER TANK	bar	6
MAXIMUM PRESSURE IN THE EXCHANGER	bar	10
MAXIMUM OPERATING TEMPERATURE IN THE TANK	°C	90
MAXIMUM OPERATING TEMPERATURE IN THE HOT WATER TANK	°C	90
MAXIMUM TEMPERATURE IN THE EXCHANGER	°C	- 110
HEAT EXCHANGER AREA	m ²	- 1.5
EXCHANGER VOLUME	l	- 10.5
HOT WATER YIELD 40°C AT TANK TEMPERATURE 53°C AND INLET WATER 15°C / HOT WATER FLOW	l/(l/min)	* 495/5
HOT WATER YIELD 40°C AT TANK TEMPERATURE 80°C AND INLET WATER 15°C / HOT WATER FLOW	l/(l/min)	* 1175/5
MAXIMUM OUTPUT OF THE ELECTRICAL HEATING ELEMENT OF SERIES TJ 6/4"	kW	1 x 3.75 + 2 x 9 1 x 3.75 + 1 x 9
ENERGY EFFICIENCY CLASS		C
STATIC LOSS	W	116

* value stated by calculation

Table 1

TYPE	NADS 800 v3	
TANK VOLUME	l	775
WEIGHT WITHOUT INSULATION	kg	100
MAXIMUM PRESSURE IN THE TANK	bar	3
MAXIMUM OPERATING TEMPERATURE IN THE TANK	°C	90
MAXIMUM OUTPUT OF THE ELECTRICAL HEATING ELEMENT OF SERIES TJ 6/4"	kW	1 x 3,75 + 3 x 9
ENERGY EFFICIENCY CLASS	C	
STATIC LOSS	116	

Table 2

4 IMPORTANT NOTICES

Connection of internal tank for hot water must comply with CSN 060830, i.e. on cold water inlet is necessary to install a safety valve.



We recommend to start up the heating circle before commissioning and to clean possible dirt caught in the filter and after this the system would be fully functional.



The appliance has to be mounted at a convenient place, it means that the appliance must be easily available for potential necessary maintenance, repair or replacement, as the case may be.

No stop fitting can be put between the security fitting of the heating circuit and the storage tank!!!



Recommended operating pressure of hot water circle is 0.4 MPa.

The reservoir is possible to use only in compliance with conditions stated on performance plate and with instructions for wiring. It is also necessary to observe terms for connection stipulated by some local electrical and water companies as same as manual for assembling and operation besides statutory accepted national regulations and standards.

Shut down the reservoir cold water intake if you are not using the reservoir for longer than 24 hours or if the object with the heater is without presence of any person.

5 TECHNICAL DESCRIPTION

NADOS 800/140 v1

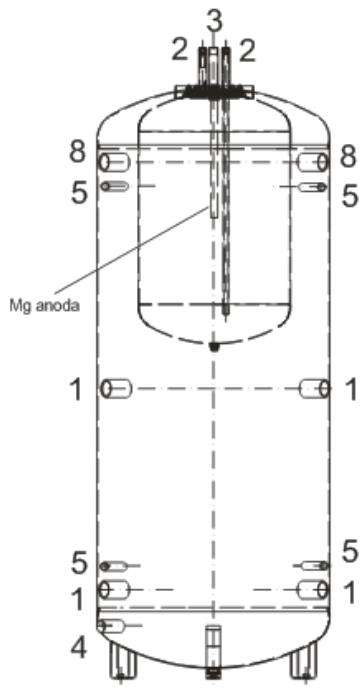

NADOS 800/140 v2

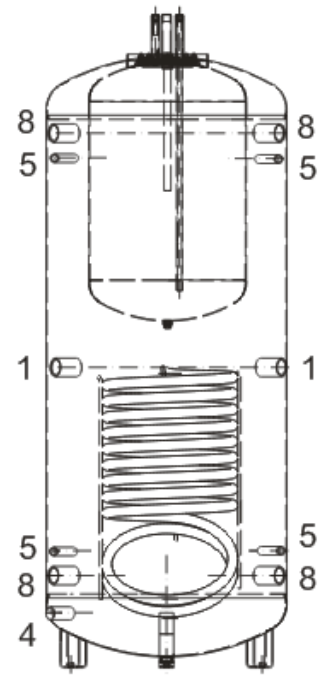
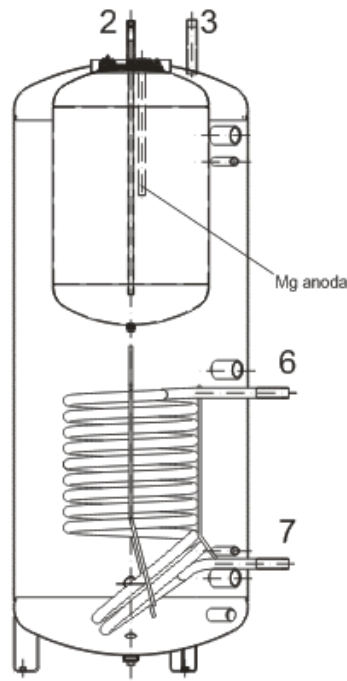

NADS 800 v3

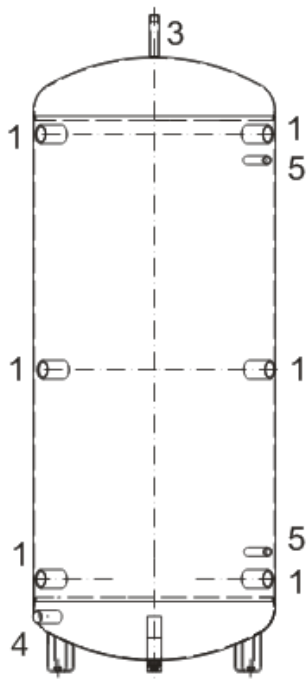

- | | | |
|----|---|--------------|
| 1. | Inlets and outlets of the storage tank, it is possible to mount a TJ body | inner G 1 ½" |
| 2. | Inlet and outlet of the DHW tank | outer G ¾" |
| 3. | Outlet of accumulated hot water (venting) | outer G 1" |
| 4. | Water outlet from the storage tank (return water) | inner G 1" |
| 5. | Sensor well (thermometer, thermostat) | inner G ½" |
| 6. | Heating water inlet | outer G 1" |
| 7. | Heating water outlet | outer G 1" |
| 8. | Inlets and outlets of the storage tank | inner G 1 ½" |

6 DIMENSIONS AND CONNECTION

NADS 800 v3

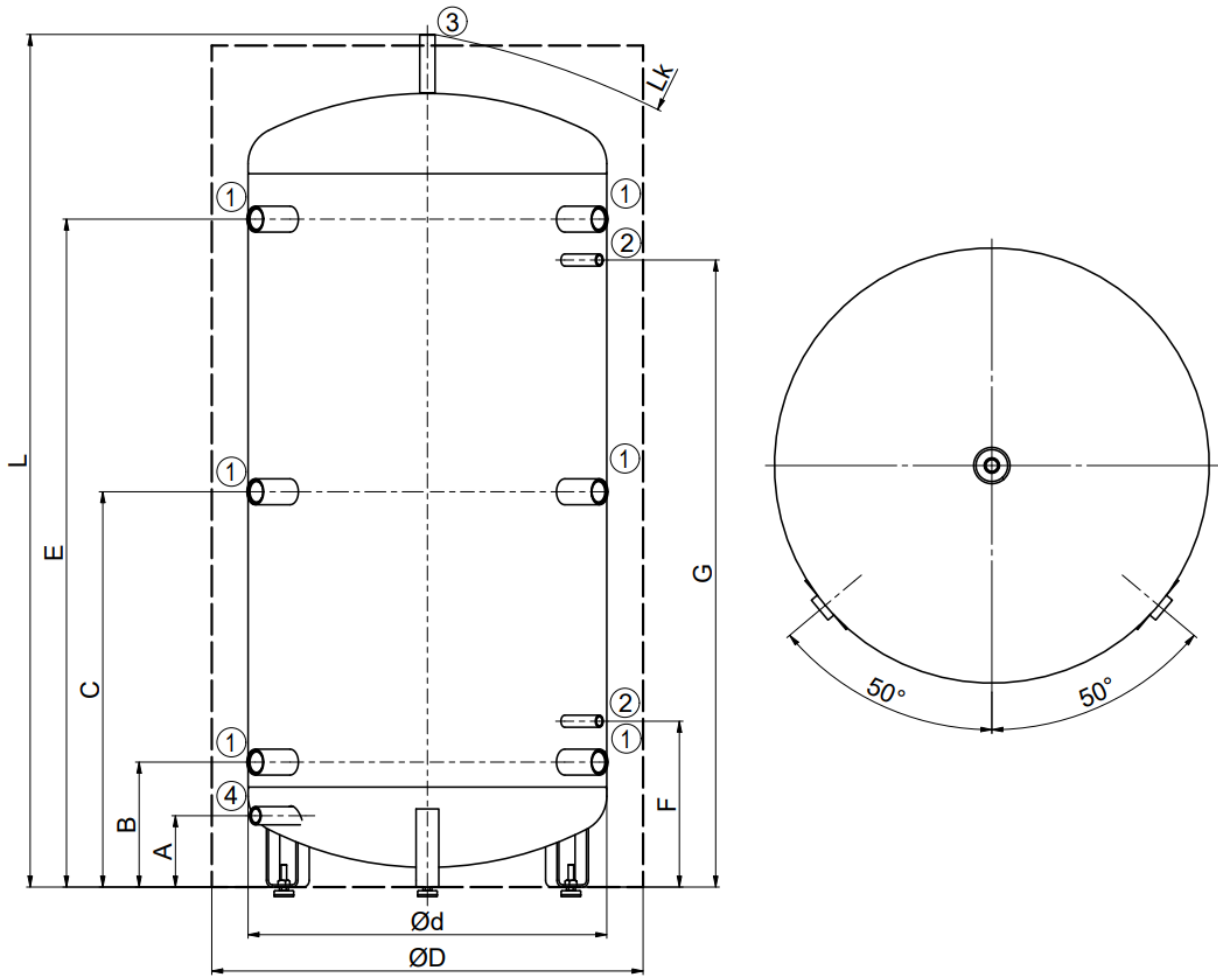

①	G 1 1/2" inner
②	G 1/2" inner
③	G 1" outer
④	G 1" inner

Figure 1

	A	B	C	d	D	E	F	G	L	Lk
NADS 800 v3	157	275	870	790	950	1470	365	1380	1880	1900

Table 3

NADOS 800/140 v1

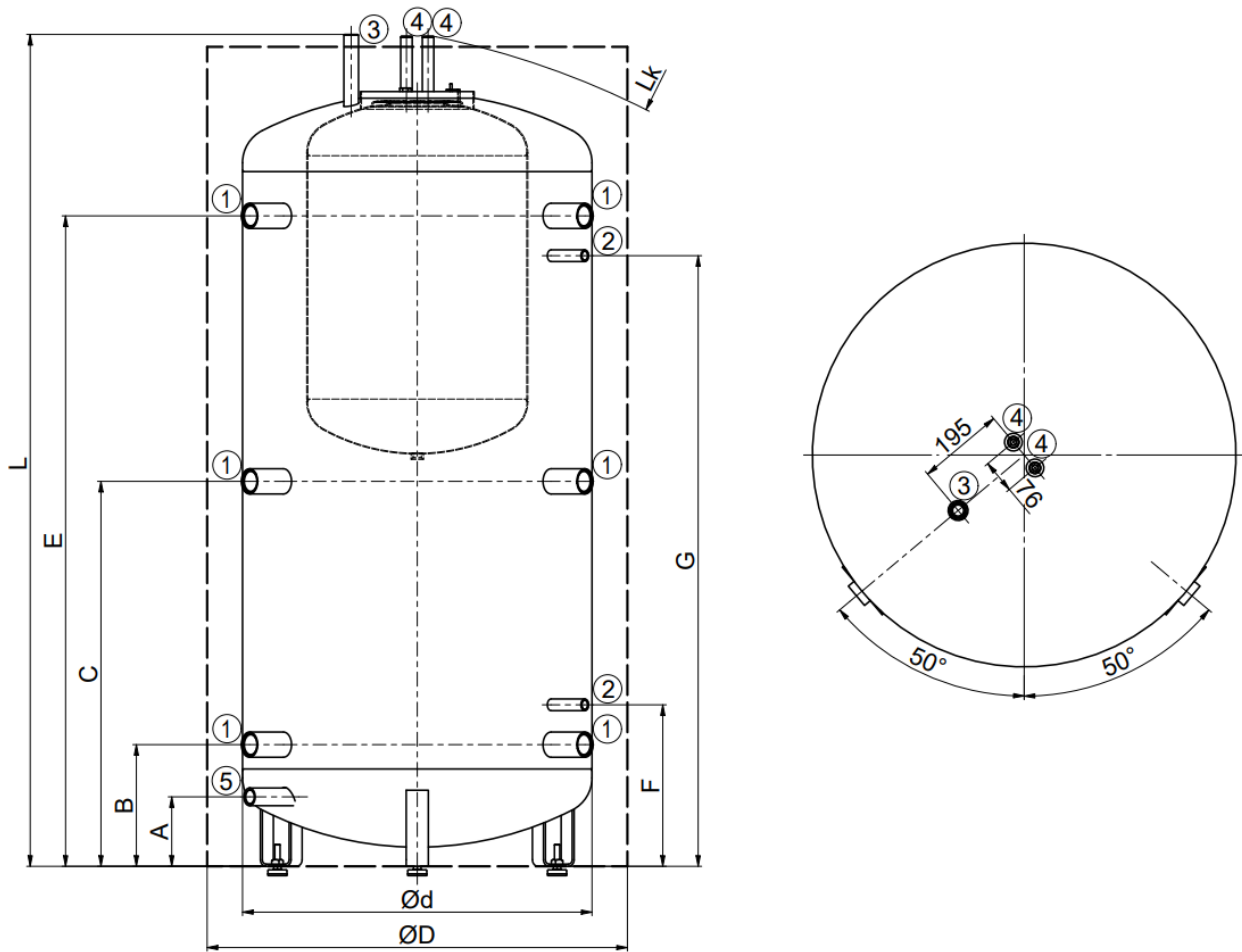

①	G 1 1/2" inner
②	G 1/2" inner
③	G 1" outer
④	G 3/4" outer
⑤	G 1" inner

Figure 2

	A	B	C	d	D	E	F	G	L	Lk
NADOS 800/140 v1	157	275	870	790	950	1470	365	1380	1880	1900

Table 4

NADOS 800/140 v2

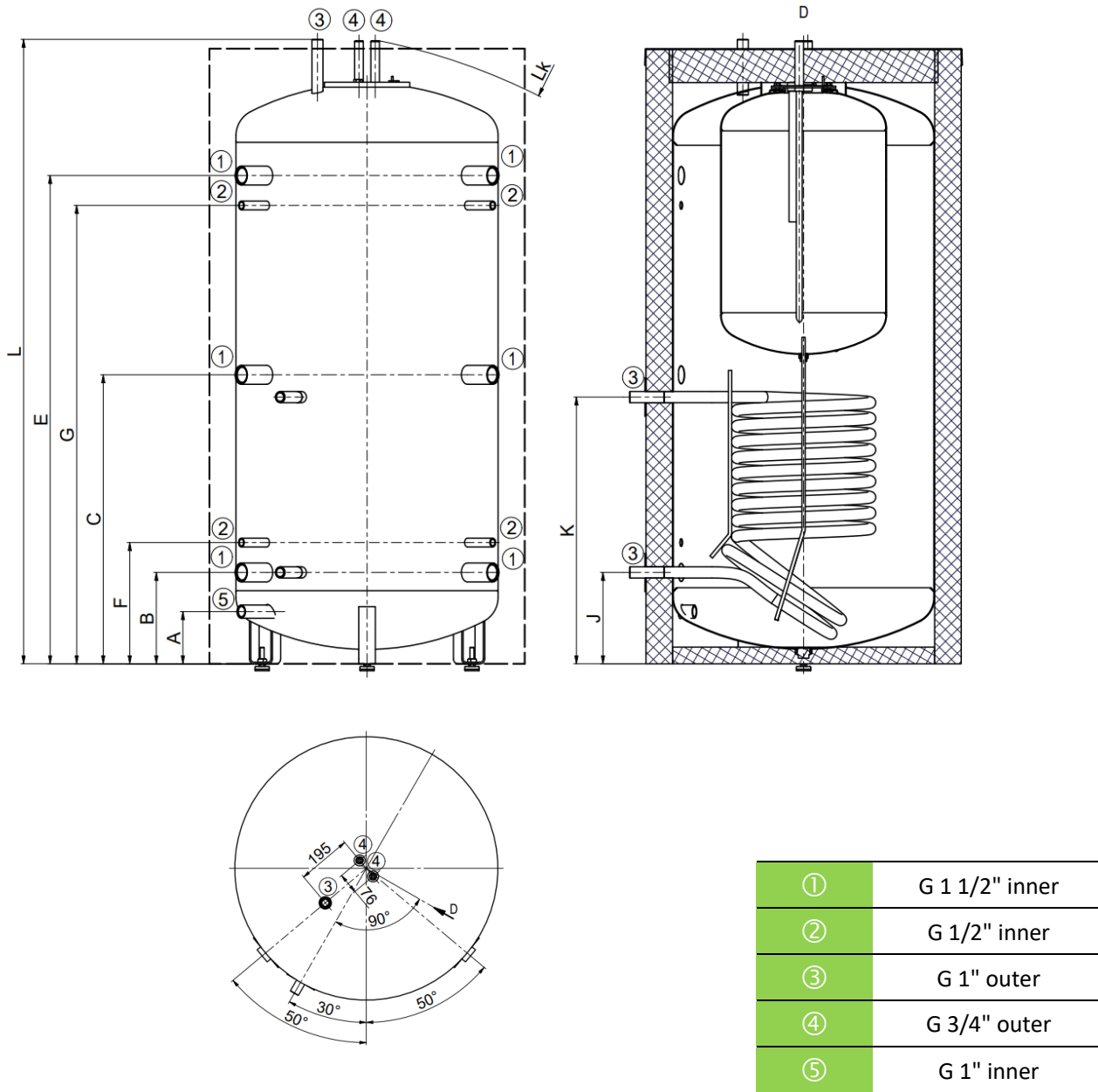

Figure 3

	A	B	C	d	D	E	F	G	J	K	L	Lk
NADOS 800/140 v2	157	275	870	790	950	1470	365	1380	275	803	1880	1900

Table 5

Thermal insulation NEODUL LB PP

Insulation NEODUL of 80 mm thickness. It consists of an upper cover, flange cover and hole caps.

We recommend that the insulation was fitted at room temperature.

At temperatures significantly below 20 °C the insulation shrinks. This disables its easy fitting.

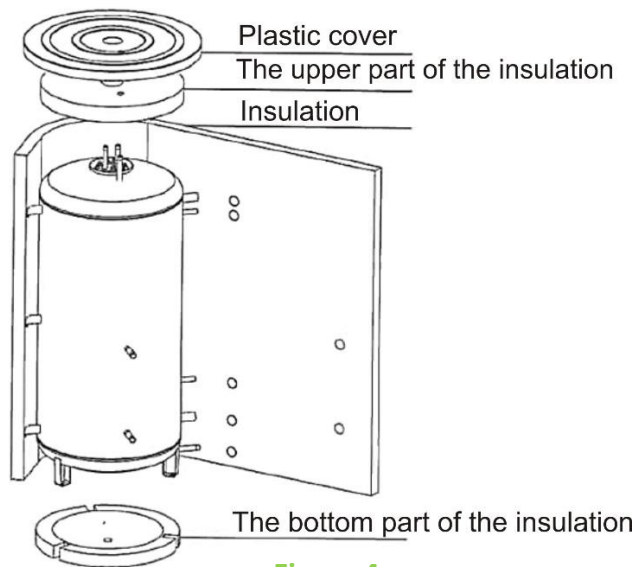

Figure 4

7 DISPOSAL OF PACKAGING MATERIAL AND NON-FUNCTIONING PRODUCT

A service fee for providing return and recovery of packaging material has been paid for the packaging in which the product was delivered. The service fee was paid pursuant to Act No 477/2001 Coll., as amended, at EKO-KOM a.s. The client number of the company is F06020274. Take the water tank packages to a waste disposal place determined by the municipality. When the operation terminates, disassemble and transport the discarded and unserviceable heater to a waste recycling center (collecting yard), or contact the manufacturer.



3-10-2024