

OPERATING AND INSTALLATION MANUAL

TANK-TYPE WATER HEATERS FOR HORIZONTAL MOUNTING

4 kW/400 V

OKCV 200

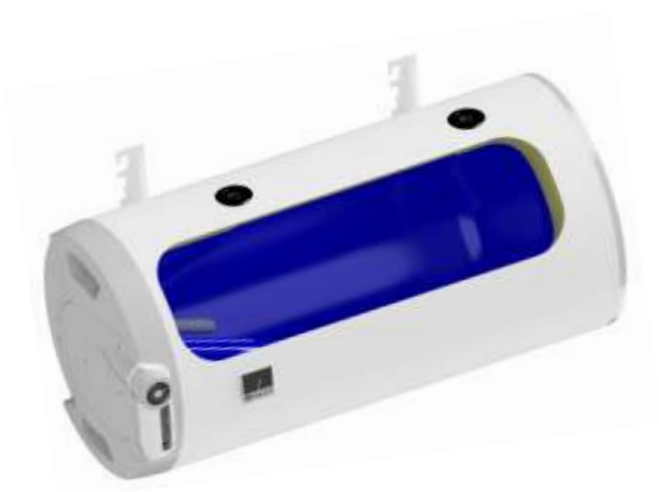

OKCEV 200



Družstevní závody Dražice-strojírna s.r.o.
Dražice 69, 294 71 Benátky nad Jizerou
tel.: +420 / 326 370 911
e-mail: export@dzd.cz

 **DRAŽICE**
NIBE GROUP MEMBER

CONTENTS

| | | |
|-------|---|----|
| 1 | PRODUCT TECHNICAL SPECIFICATION | 4 |
| 1.1 | FUNCTION DESCRIPTION | 4 |
| 1.1.1 | OPERATING ACTIVITY..... | 4 |
| 1.2 | ADVICE FOR CUSTOMERS | 4 |
| 1.2.1 | HOT WATER CONSUMPTION | 4 |
| 1.2.2 | ENERGY SAVING..... | 5 |
| 1.2.3 | EMERGENCY POWER CONSUMPTION | 5 |
| 1.3 | DESIGN AND GENERAL HEATER DIMENSIONS..... | 5 |
| 2 | OPERATION AND FITTING INSTRUCTIONS..... | 9 |
| 2.1 | OPERATING CONDITIONS | 9 |
| 2.2 | WALL MOUNTING..... | 9 |
| 2.3 | PLUMBING FIXTURE..... | 10 |
| 2.4 | ELECTRICAL INSTALLATION..... | 12 |
| 2.4.1 | GENERAL INFORMATION FOR ELECTRICAL INSTALLATION | 12 |
| 2.5 | CONNECTION OF INDIRECT HEATER TO HOT WATER SYSTEM..... | 12 |
| 2.6 | FIRST COMMISSIONING..... | 14 |
| 2.7 | PUTTING OUT OF SERVICE, DISCHARGE | 14 |
| 2.8 | INSPECTION, MAINTENANCE & CARE FOR THE APPLIANCE | 15 |
| 2.9 | MOST FREQUENT FUNCTION FAILURES AND THEIR CAUSES | 16 |
| 3 | OPERATION OF THERMOSTAT | 17 |
| 3.1 | OPERATING DEVICES OF THE HEATER | 17 |
| 3.1.1 | TEMPERATURE SETTING | 17 |
| 4 | IMPORTANT NOTICES | 18 |
| 4.1 | INSTALLATION REGULATIONS..... | 18 |
| 4.2 | TRANSPORT & STORAGE INSTRUCTIONS | 19 |
| 4.3 | DISPOSAL OF PACKAGING MATERIAL AND NON-FUNCTIONING PRODUCT..... | 19 |
| 5 | PRODUCT ACCESSORIES | 19 |

CAREFULLY READ THIS MANUAL BEFORE INSTALLING THE WATER HEATER!

Dear Customer,

Družstevní závody Dražice - strojírna s.r.o., would like to thank you for your decision to use a product of our brand. With this guide, we will introduce you to the use, construction, maintenance and other information on electrical water heaters.



The product is not intended to be controlled by

- a) people (including children) with reduced physical, sensual or mental capacities, or
- b) people with insufficient knowledge and experiences unless supervised by responsible person, or unless properly instructed by such responsible person.

The manufacturer reserves the right for engineering modification of the product. The product is designed for permanent contact with drinkable water.

It is recommended to use the product in indoor environment with air temperatures from +2 °C to +45 °C and a relative humidity up to 80 %.

Product's reliability and safety is proven by tests implemented by the Engineering Test Institute in Brno.

Made in the Czech Republic.

Meaning of pictograms used in the Manual



Important information for heater users.



Abiding by the recommendations of the manufacturer serves to ensure trouble-free operation and the long service life of the product.



Caution!
Important notice to be observed.

1 PRODUCT TECHNICAL SPECIFICATION

1.1 FUNCTION DESCRIPTION

Tank type water heater (the heater hereinafter) is designed for the accumulation heating of service water using electricity or thermal energy via an exchanger (for the combined design only). Water is heated by an electric element (or a heat exchanger) in an enameled thermally insulated accumulator at the time defined by the power supplier. The element is at the time of heating controlled by a thermostat the temperature of which can be adjusted continuously (within the range between 5 °C and 75 °C). Once the selected temperature is reached, heating interrupts automatically. Water accumulated in the tank is then used for the consumption. The tank keeps constant pressure of water from the water main. If the combination faucet hot water valve is opened, water from the water supply conduit pressed out by cold water pressure flows out of the heater. Hot water flows out through the top part, and water flowing in remains in the bottom part of the heater. Pressure principle allows hot water withdrawal at any place from the heater.

1.1.1 OPERATING ACTIVITY

a) Water heating by electric energy

After the heater is connected to electric network, the heating element starts heating water. The element is turned on and off by a thermostat. After reaching the temperature set, the thermostat switches off the electric circuit and discontinues water heating. The control light signals if the element is in operation (light is on) or if it is off (the light goes out). In case of longer operation without using the heated volume, the thermostat has to be set to position 5 °C to 10 °C (set the “snowflake” symbol on the thermostat selector) to avoid its freezing, or electricity supply to the heater has to be switched off. In combined versions, the stop valve on the inlet to the exchanger has to be closed at the inlet to the heat exchanger while heating using el. energy, which prevents heating water in the hot water heating system.

b) Service water heating via thermal energy through heat exchanger

Closing valves of the heat exchanger must be opened which ensures heating water flow from the hot water heating system. Along with a closing valve at the inlet to the heat exchanger, it is recommended to install an air removal valve, in order to bleed the heat exchanger as needed, in particular before the beginning of the heating season. The time it takes to heat up using the heat exchanger depends on the temperature and flow of water in the hot water heating system.

1.2 ADVICE FOR CUSTOMERS

1.2.1 HOT WATER CONSUMPTION



Consumption of hot water in households depends on the number of people, amount of sanitary equipment, length, diameter and insulation of piping in the flat, or on individual habits of users. The cheapest option of water heating comes at the time when the electricity rate is reduced.



Find out in what time intervals your electricity supplier provides reduced tariff and, depending on that information, select relevant volume and power input of the heater so that your hot water consumption covered the needs of your household.

1.2.2 ENERGY SAVING



The heater is insulated with quality polyurethane Freon free foam. Set the temperature of the heater's thermostat to that level only that you need to run your home. Thus, you will reduce electricity consumption, as well as the amount of lime sediments on the walls of the receptacle and on the electric body.

1.2.3 EMERGENCY POWER CONSUMPTION



According to current legislation, the standby consumption is stated in the value of annual consumption of electric energy (kWh), which is measured according to the corresponding load profile and calculated according to the formulas and requirements of EU Regulation No. 812/2013.

| HEATER TYPE | NOMINAL CAPACITY [L] | TIME OF CONTENT HEATING [hours] | ELECTRICITY CONSUMPTION FOR HEATING THE VOLUME FROM 15°C TO 65°C [kWh] |
|---------------------|----------------------|---------------------------------|--|
| OKCV 200; OKCEV 200 | 201 | 2.9 | 12 |

Table 1

1.3 DESIGN AND GENERAL HEATER DIMENSIONS

The heater tanks are made of a steel plate and tested by 1.5 multiple of operation pressure value. The inside of the receptacle is enameled. A flange is welded onto the bottom of the tank with a flange lid screwed to it. A sealing ring is inserted between the flange lid and the flange. Thermowells for placing a heating element and sensors of regulation thermostat and safety fuse are located in the flange lid. An anode rod is mounted onto the M8 nut. The water reservoir is insulated by means of polyurethane foam. Electric wiring is placed underneath the plastic removable cover. The temperature of water can be set using the thermostat. In combined versions, a heat exchanger is **welded** in the pressure tank. The heat exchanger is only intended for the heating circuit. Heater types OKCV 200 are produced in the right and left design.

Heater dimensions - Figure 1, Figure 2, Figure 3 and Table 3, Table 4.

| TYPE | | OKCV 200 OKCEV 200 |
|--|----------------|-----------------------|
| VOLUME | l | 201 |
| MAX OPERATING OVERPRESSURE IN THE TANK | bar | 6 |
| MAX OPERATING OVERPRESSURE IN THE EXCHANGER * | bar | 4 |
| ELECTRICAL CONNECTION | | 3 PE-N ~ 400 V/50Hz |
| INPUT | W | 4000 |
| EL. PROTECTION | | IP 42 |
| MAX WARM WATER TEMPERATURE | °C | 80 |
| RECOMMENDED WARM WATER TEMPERATURE | °C | 60 |
| HEIGHT OF THE HEATER | mm | 1290 |
| DIAMETER OF THE HEATER | mm | 584 |
| MAX WEIGHT OF THE HEATER WITHOUT WATER | kg | 86 72 |
| TIME OF EL. HEATING FROM 10°C TO 60°C* | hours | 2.9 |
| MIXED WATER V40 | l | 301.93 |
| LOAD PROFILE | | XL |
| ENERGY EFFICIENCY CLASS | | C |
| ENERGY EFFICIENCY | % | 39 |
| ANNUAL CONSUMPTION OF ELECTRIC ENERGY | kWh | 4324 |
| TYPE | | OKCV 200 |
| EXCHANGER HEAT TRANSFER SURFACE | m ² | 0.75 |
| RATED THERMAL OUTPUT AT HEATING WATER TEMPERATURE OF 80°C AND FLOW 720 l/h | W | 18000 |
| TIME OF HEATING BY EXCHANGER FROM 10°C TO 60°C | min | 43 |
| RATED THERMAL OUTPUT AT HEATING WATER TEMPERATURE OF 80°C AND FLOW 310 l/h | W | 11000 |
| TIME OF HEATING BY EXCHANGER FROM 10°C TO 60°C | min | 72 |

* OKCEV series heaters do not include the heat exchanger.

Table 2

OKCEV 200

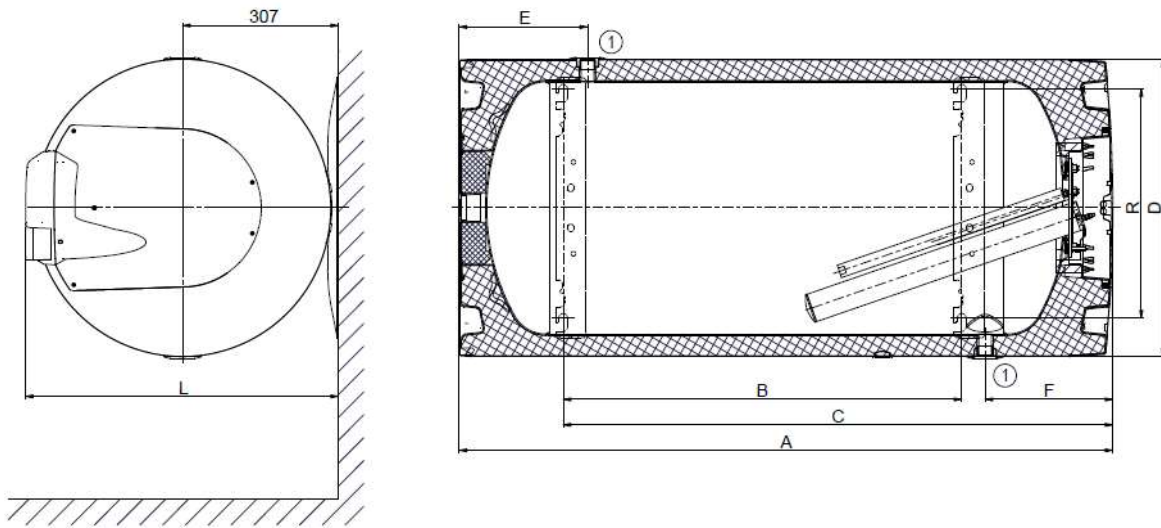

Figure 1

| OKCEV 200 | |
|-----------|-----------------|
| A | 1290 |
| B | 785 |
| C | 1082 |
| D | 584 |
| E | 253 |
| F | 251 |
| L | 617 |
| R | 450 |
| ① | neck 3/4" inner |

Table 3

OKCV 200 – right design

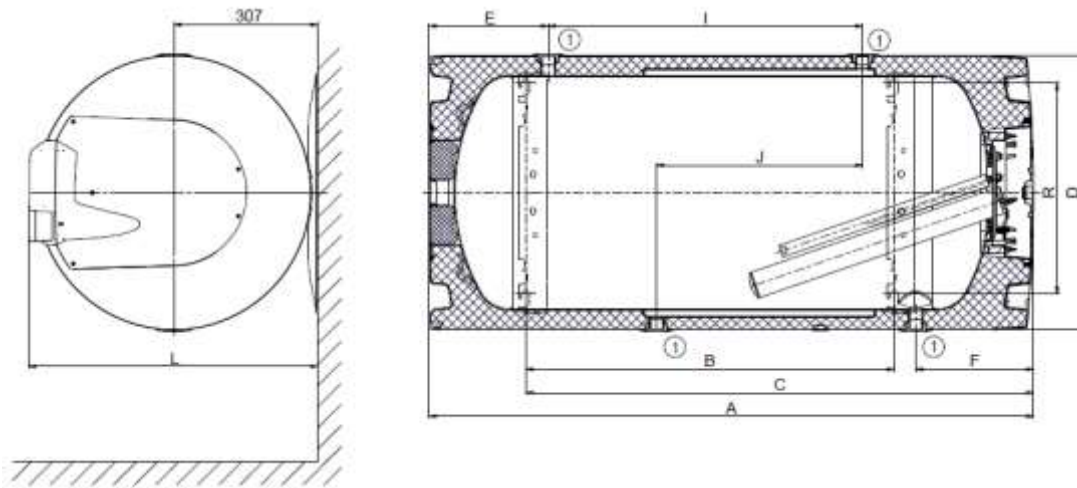

Figure 2

OKCV 200 – left design

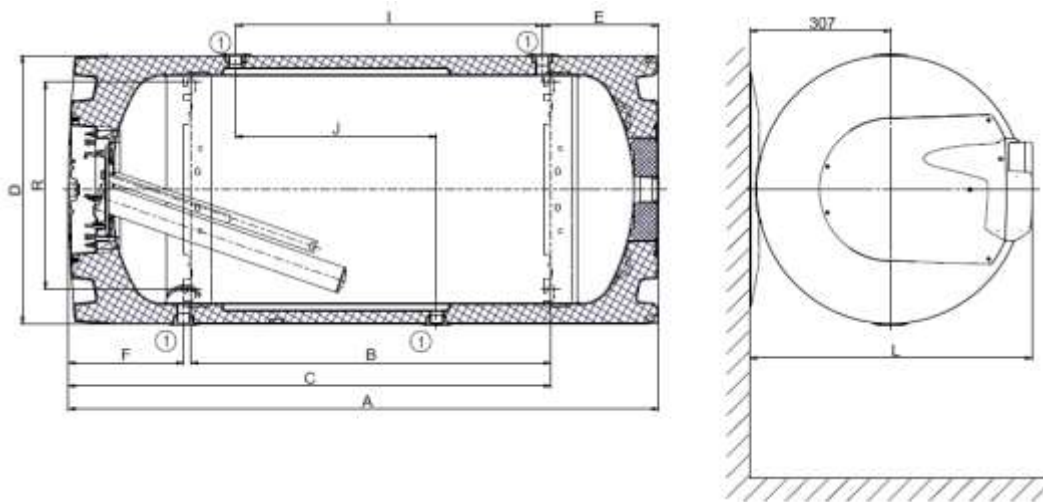

Figure 3

| OKCV 200 | |
|----------|-----------------|
| A | 1290 |
| B | 785 |
| C | 1082 |
| D | 584 |
| E | 253 |
| F | 251 |
| I | 670 |
| J | 439 |
| L | 617 |
| R | 450 |
| ① | neck 3/4" inner |

Table 4

2 OPERATION AND FITTING INSTRUCTIONS

2.1 OPERATING CONDITIONS



The tank shall only be used in accordance with the conditions specified on the power plate and in instructions for electric wiring. Besides legally acknowledged national regulations and standards, also conditions for connection defined in local electric and water works have to be adhered to, as well as the installation and operation manual. The room, in which the appliance will be operated, must be frost-free. The appliance has to be mounted at a convenient place; it means that the appliance must be easily available for potential necessary maintenance, repair or replacement, as the case may be.

We would like to emphasize that the heater must not be connected to power supply if work involving flammable liquids (petrol, spot remover) or gases, etc., is performed nearby.



If water is strongly calcareous we recommend that any of the common decalcifying devices was installed with the appliance, or that the thermostat was set to the minimum operating temperature of 55 °C (setting to position „OPTIMUM“) - Figure 10. For proper operation, drinkable water of adequate quality shall be used. To avoid potential sediments, we recommend that the device was installed together with a water filter.

2.2 WALL MOUNTING



Prior to mounting, check the loading capacity of the wall and, depending on the type of masonry, choose a suitable anchorage material, or reinforce the wall, if needed. The water heater shall only be mounted in horizontal position so that the electrical installation cover of the heater was placed at least 600 mm from the opposite side. In combined and electric heaters, elbows have to be attached to the hot service water inlet and outlet prior to their suspension in brackets right under the ceiling and, by turning these elbows, mounting left has to be determined - either from the right, or from the left. **With regard to various types of carrying masonry and broad assortment of special anchorage material available at the market, we do not provide heaters with the anchoring material.** The anchorage system has to be selected individually, depending on the conditions. We recommend entrusting wall mounting and anchoring to a specialist company or discussing the anchorage with an expert. The minimum diameter of the bolts for suspending the heater is **12 mm**.



If the hot water heater is mounted in a **tight, small space**, or in an intermediate ceiling, etc., you have to make sure that the connecting side of the appliance (connections to water supply, area for electric plugging) remained accessible and no heat accumulation occurs.

2.3 PLUMBING FIXTURE



The heater connects to water distribution tubes with G 3/4". The cold water supply to the water supply is always at the bottom of the container on the side near the electric controller. Examples of connection see Figure 7 and Figure 8 on page 13. For potential disconnection of the heater, the service water inlets and outlets must be provided with screw coupling Js 3/4". The safety valve is mounted on the cold water inlet.



The heater must be equipped with a membrane, spring-loaded safety valve. Safety valves with fixed pressure settings from the manufacturer are used for the assembly. Each individually lockable heater must be fitted with a cap on the cold water inlet, a test valve or a stopper to check the operation of the check valve, with a check valve and a relief valve (Figure 4, Figure 5). **The safety valve with a check valve is supplied with the heater.**



It is necessary to check the safety valve each time before putting it into operation. It is checked by manual moving of the membrane from the seat, turning the make-and-break device button always in the direction of the arrow. After being turned, the button must click back into a notch. Proper function of the make-and-break device results in water draining through the safety valve outlet pipe. In common operation, such a check needs to be implemented at least once a month, and after each heater shutdown for more than 5 days. Water may be dripping off the drain pipe of the safety valve; the pipe must be open into the air, pointed down; environment temperatures must not drop below zero.

Find necessary pressure values in the below - Table 5.

Heaters must be provided with a discharge valve mounted on the cold service water inlet to the heater for potential disassembly or repair. **When assembling the security equipment, follow the standard.**

| SAFETY VALVE START-UP PRESSURE [MPa] | ALLOWABLE OPERATING OVERPRESSURE OF WATER HEATER [MPa] | MAXIMUM PRESSURE IN COLD WATER PIPES [MPa] |
|--------------------------------------|--|--|
| 0.6 | 0.6 | up to 0.48 |

Table 5

OKCV 200

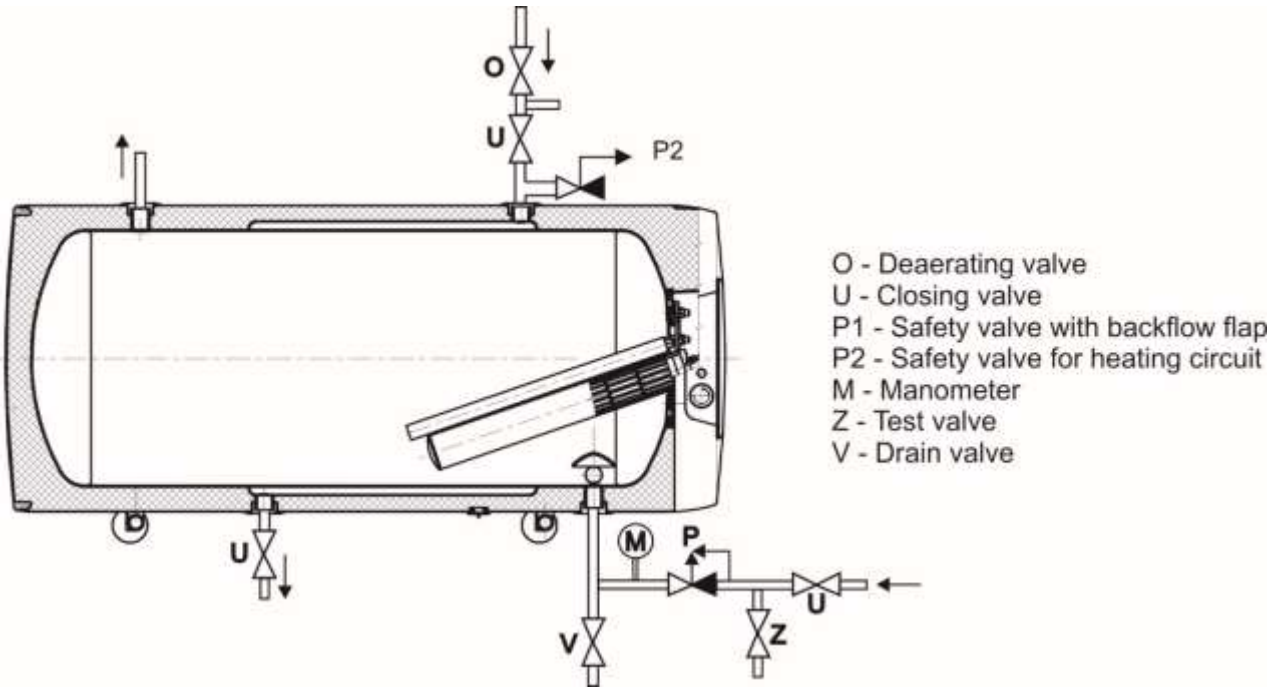

Figure 4

OKCEV 200

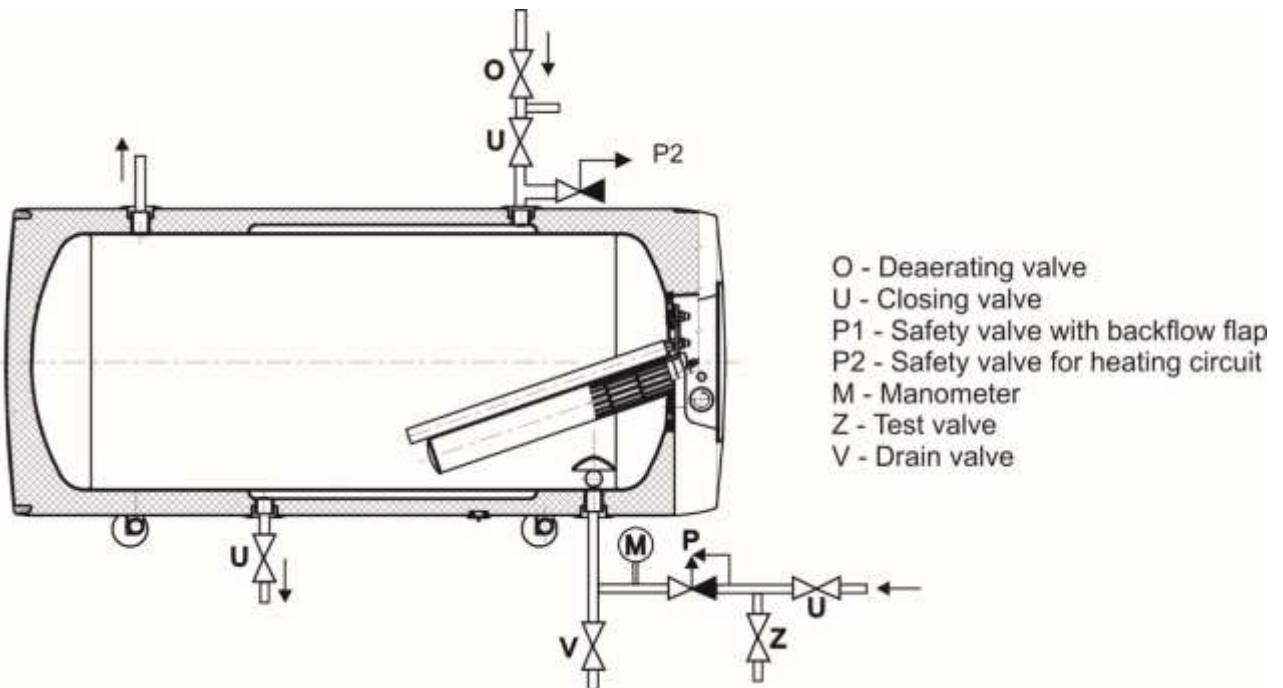

Figure 5

2.4 ELECTRICAL INSTALLATION

2.4.1 GENERAL INFORMATION FOR ELECTRICAL INSTALLATION



- The electric wiring scheme is attached to the water heater on the side of the electric installation guard (Figure 6)
- Connection, repairs, and wiring inspections may only be implemented by a company (person) authorized to such activity.
- Expert connection must be confirmed on the warranty certificate.
- The heater is connected to the 400 V/50 Hz electrical network using a fixed moving conductor with the circuit breaker (protector).
- Installations in bathrooms, laundry rooms, rest rooms and showers, must be in compliance with standard.
- The degree of protection of electric parts of the heater is IP 44.
- Adhere to the protection against electric shock injury according to standard.

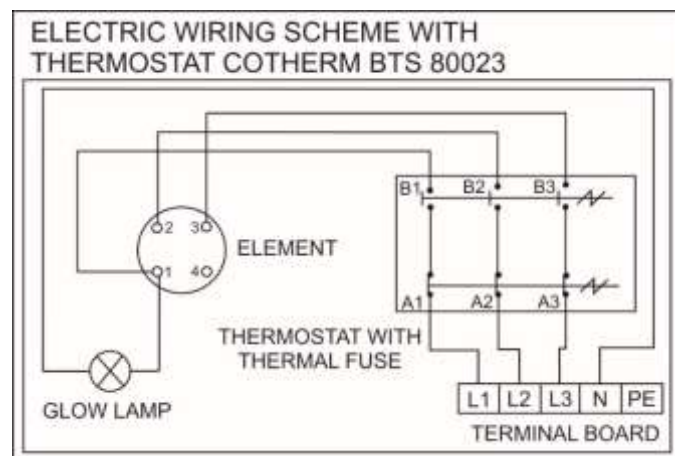

Figure 6

2.5 CONNECTION OF INDIRECT HEATER TO HOT WATER SYSTEM



It is recommended to install stop valves on the heating water inlet and outlet (for possible dismantling of the heater). The valves have to be as close to the heater as possible to avoid higher thermal losses (Figure 4, Figure 5, Figure 7 and Figure 8).

TANK TYPE COMBINED WATER HEATER HOT WATER DISTRIBUTION

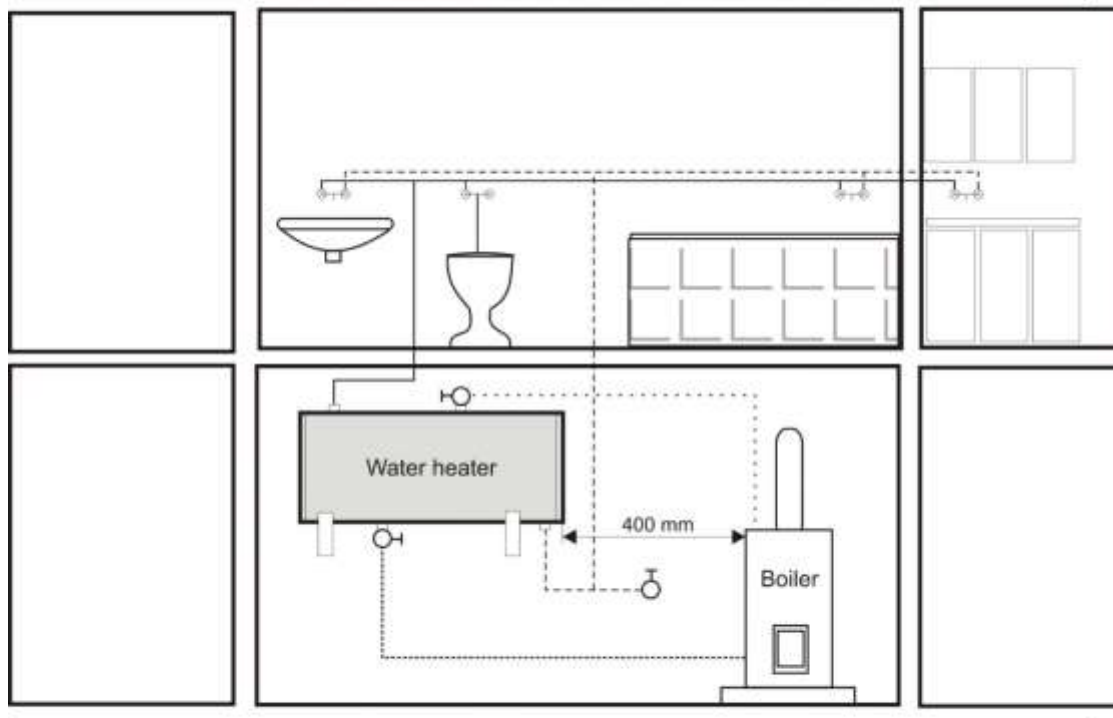
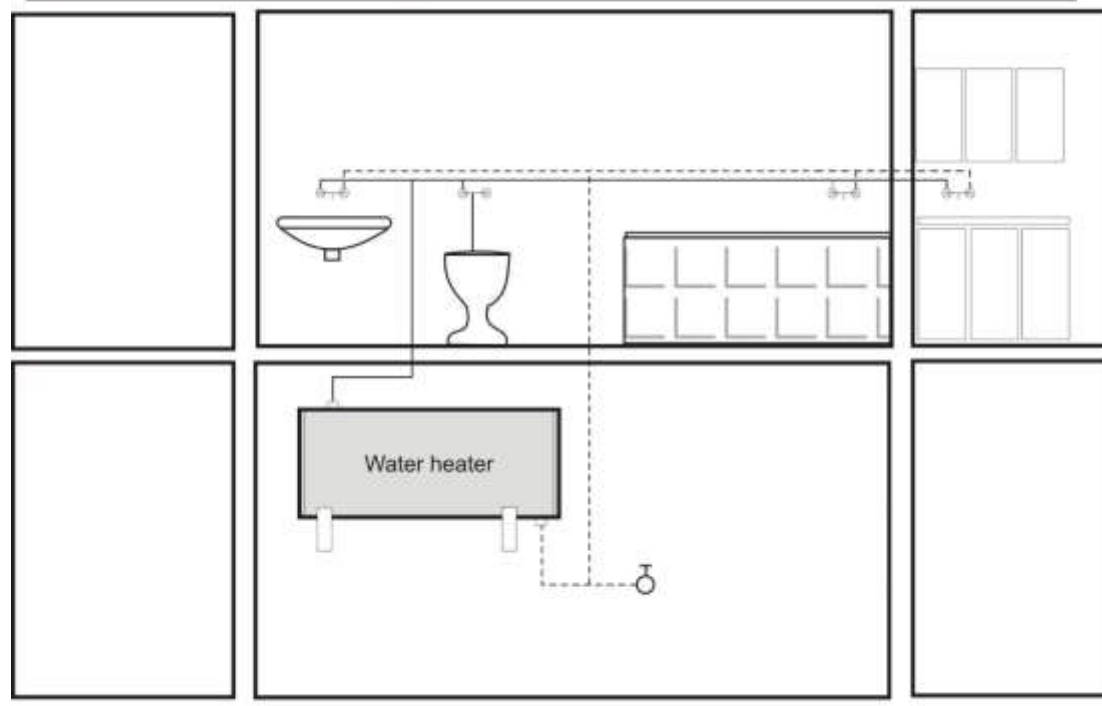

Figure 7

— Hot water
 - - - Cold water
 ····· Heating circuit
 ····· Return circuit

TANK TYPE ELECTRIC WATER HEATER HOT WATER DISTRIBUTION



— Hot water
 - - - Cold water

Figure 8

2.6 FIRST COMMISSIONING



After connecting the heater to the water supply, the hot water heating system, the electric network, and after testing its safety valve (based on the valve manual attached), the heater may be put into operation. Before opening the power supply, the tank must be filled with water. The process of first heating must be executed by licensed professional who has to check it. Both the hot water outlet pipe and safety armature parts may be hot.



During the heating process the pressurized connection water that increases its volume due to heating must drip off the safety valve. In non-pressurized connection water drips off the overflow combination faucet. When heating is finished, the set temperature and the actual temperature of consumed water must be more-or-less the same. After connecting the heater to the water main and electrical power system, and after checking the safety valve (following the instructions attached to the valve), the heater can be put into operation.

Procedure of putting the heater into operation:

1. Check both water and electric installation; for combined heaters, check the installation to a hot water heating system. Check proper placement of operating and safety thermostat sensors. Sensors has to be installed in to the sink as deep as possible - following the possibilities of each capillary, controlling thermostat has to be installed as first sensor in to the capillary, following by the safety thermostat as the second sensor installed in to the capillary.
2. Open the hot water valve on the combination faucet.
3. Open the cold water inlet valve to the heater.
4. As soon as the water starts running through the hot water valve, the heater is filled, and the valve can be closed.
5. In case of leakage (of flange lid), we recommend that the flange lid bolts are fastened. Screws has to be tightened by cross, tightening moment 15Nm.
6. Screw down the electric installation guard.
7. When hot sanitary water is heated by electric energy, switch on the power supply (the valve on the heating water inlet to the heating insert must be closed in combined heaters).
8. When sanitary water is heated with electric energy from the hot water heating system, turn off electricity an open the valves on the heating water inlet and outlet, possibly de-aerate the exchanger.
9. When commencing operation, flush the heater until the cloudiness in the water is gone.
10. Make sure to fill in properly the warranty certificate.

2.7 PUTTING OUT OF SERVICE, DISCHARGE



If the hot water heater is put out of service for a longer time, or if it is not going to be used it has to be drained and disconnected from the electric supply network. The switch for the supply lead or the fuse cut-outs has to be shut off.

At places with permanent risk of frost the hot water heater must be drained before the cold season starts if the appliance remains out of service for several days and if the power supply is disconnected.



Drainage of service water shall be performed after closing the shut-off valve in the cold water supply piping (through the discharge valve for safety valve combination), and with simultaneous opening of all hot water valves of connected fittings (water can be also drained through safety valve; for that purpose, the safety valve is turned to the "Check" position). **Hot water may outflow during the drainage!** If there is a risk of frost it has to be considered that not only the water in the hot water heater and in the hot water piping may get frozen but also the water in the entire cold water supply piping. It is therefore advisable to drain all fittings and piping that carry water, up to the part where the house water meter is installed (connection of the house to water main) which is not jeopardized by frost. When the tank is to be used again, it has to be filled with water and one needs to make sure that the water flowing out at the **hot water valves did not contain any bubbles.**

2.8 INSPECTION, MAINTENANCE & CARE FOR THE APPLIANCE



During the heating process the water that increases its volume during the heating must visibly drip off the safety valve outlet (in non-pressurized connection this water drips off the combination faucet valve). In full heating (about 75 °C) the volumetric water gain is approx. 3 % of the tank capacity. The function of the safety valve has to be checked regularly. If the safety valve control knob is lifted or turned to the "Control" position, the water must flow out easily, without any obstacles, from the safety valve element to the outfall line. In common operation, such a check needs to be implemented at least once a month, and after each heater shutdown for more than 5 days.



Attention! In doing so, the cold water supply pipe and the connection fitting of the tank may get heated! If the hot water heater does not work, or if hot water is not withdrawn, no water shall drip off the safety valve. If water drips, then the water pressure in the supply piping is either too high (if higher than 4.8 bars, a pressure control valve has to be fitted), or the safety valve is defective. Please call a specialized plumber immediately!



If water contains too many minerals, an expert has to come to remove the scale that forms inside the tank, as well as free sediments. This has to be performed after one or two years of operation. The cleaning is carried out through the hole in the flange - dismantle the flange lid and clean the tank. A new sealing has to be used for re-fitting. Since the inside of the heater has special enamel, which must not get in contact with the scale removing agent - do not work with a lime pump. Remove the lime layer with a timber and suck it off or wipe it off with a clout. After that, the appliance must be rinsed thoroughly, and the heating process is checked the same as during the initial putting in operation. Do not use any abrasive cleaning agents (such as liquid sand, chemicals - acid, alkaline) or dye thinners (such as cellulose thinner, trichlor, and the like) to clean the outer shell of the heater. For cleaning use a wet clout and add a few drops of liquid cleaning agent for household applications. Repeated heating causes lime scale settling on the receptacle walls and mostly on the lid of the flange. Lime scale settling depends on hardness of heated water, its temperature and on the volume of hot water used.

We recommend checking and cleaning the tank from scale and eventual replacement of the anode rod after two years of operation. The anode life is theoretically calculated for two years of operation; however, it changes with water hardness and chemical composition in the place of use. Based on such an inspection, the next term of anode rod exchange may be determined. If the anode is only blocked with sediments clean its surface and, if used up, mount a new one. Have a company in charge of service affairs deal with the cleaning and exchanging of the anode. When draining water from the heater, the combination faucet valve for hot water must be open, preventing occurrence of under-pressure in the heater tank which would stop the water from draining.

2.9 MOST FREQUENT FUNCTION FAILURES AND THEIR CAUSES

| FAILURE SYMPTOM | INDICATOR | SOLUTION |
|---|---|--|
| Water is cold | <ul style="list-style-type: none"> • Light on | <ul style="list-style-type: none"> • The temperature set on the thermostat is too low • Heating element failure |
| Water is cold | <ul style="list-style-type: none"> • Light off | <ul style="list-style-type: none"> • No supply voltage! • Thermostat failure • Safety thermostat shut off probably due to failed operation thermostat |
| Water is not warm enough | <ul style="list-style-type: none"> • Light on | <ul style="list-style-type: none"> • Failure of one of the coils in the element (contains 2) |
| Temperature of water is not corresponding with the set value | | <ul style="list-style-type: none"> • Defective thermostat |
| Water is constantly dripping off the safety valve | <ul style="list-style-type: none"> • Light off | <ul style="list-style-type: none"> • High input pressure • Defective safety valve |

Table 6



Do not attempt to repair the failure yourselves. Seek either expert or service help. It does not take much for an expert to remove the defect. When making a repair appointment, report the type and serial number you find on the performance plate of your water heater.

3 OPERATION OF THERMOSTAT

3.1 OPERATING DEVICES OF THE HEATER

Electrical installation cover for heaters OKCV 200, OKCEV 200

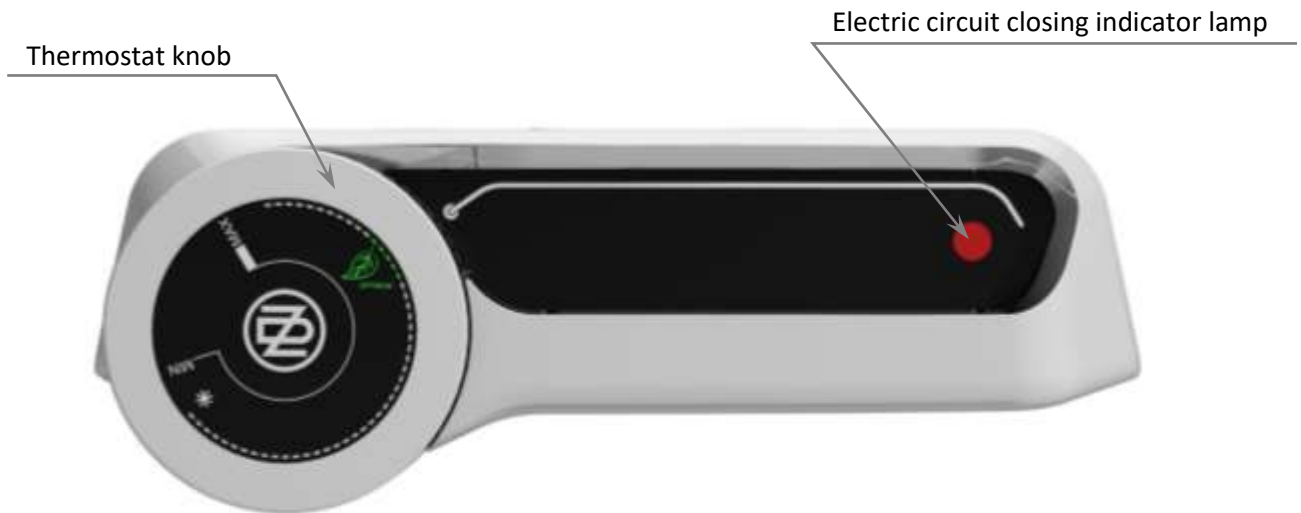

Figure 9



Thermostat and no other part of the control panel is not a bearing part which can be used for any handling with the heater.

3.1.1 TEMPERATURE SETTING

Water temperature is set by turning the thermostat knob. The desired symbol is adjusted against the fixed mark on the control panel (Figure 10).



Figure 10



Adjusting the thermostat knob to the left backstop does not mean permanent shutoff of the heating element. When the heater is in use without blocking the daily rate, we do not recommend the temperature to be set above 55 °C. Select the "**OPTIMUM**" symbol as the maximum.

4 IMPORTANT NOTICES

4.1 INSTALLATION REGULATIONS

- **Without a confirmation of performed electrical installation issued by an authorized company, the warranty certificate shall be void.**
- Check and exchange the Mg anode regularly.
- You have to apply for approval of a local power supplier to connect the heater.
- **No stop valves can be put between the heater and the safety valve.**
- If the overpressure in the water main exceeds 0.48 MPa, a pressure control valve must be mounted before the safety valve.
- All hot water outputs must have a combination faucet.
- Before filling the heater with water for the first time, it is recommended to fasten the flange connection nuts of the tank. Screws has to be tightened by cross, tightening moment 15Nm.
- It is not allowed to handle the thermostat, aside from temperature resetting with a control button.
- All electric installation handling, adjustment and replacement of the regulation elements shall only be performed by an authorized service company.
- **The thermal fuse must not be turned off!** In case of thermostat defect, the thermal fuse interrupts electric power input to the heating element if the water temperature in the heater exceeds 90 °C.
- As an exception, the thermal fuse may also switch off due to water overheating caused by overheating the hot water heating system boiler (in case of a combined heater).
- We recommend you operate the heater with one type of energy.
- If you don't use the heater (hot water tank) for longer than 24 hours, or if the facility with heater is unattended, close the cold water inlet to the heater.
- The heater (hot water tank) shall be used exclusively in accordance with the conditions specified on the performance plate and in the instructions for electric wiring.



Both the electric and water installation must follow and meet the requirements and regulations relevant in the country of use!

4.2 TRANSPORT & STORAGE INSTRUCTIONS

The device shall be transported and stored in dry place and protected from weather effects with temperature range from -15 to +50 °C. During loading and unloading the instructions stated on the packaging shall be observed.



Due to the transport and thermal dilating, excessive enamel may fall of the heaters with exchangers on the tank bottom. This occurrence is common and has no effects on the heater's service life and quality. The decisive enamel layer which remains in the vessel. DZD has many years of experience with this occurrence, and it is not a reason for complaints.

4.3 DISPOSAL OF PACKAGING MATERIAL AND NON-FUNCTIONING PRODUCT

A service fee for providing return and recovery of packaging material has been paid for the packaging in which the product was delivered. The service fee was paid pursuant to Act No 477/2001 Coll., as amended, at EKO-KOM a.s. The client number of the company is F06020274. Take the water boiler packages to a waste disposal place determined by the town. When the operation terminates, disassemble and transport the discarded and unserviceable heater to a waste recycling center (collecting yard), or contact the manufacturer.



5 PRODUCT ACCESSORIES

The product is supplied together with a safety valve and a thermometer. The above parts are packed and placed in the packaging in the top part of the heater.

It is in your own interest to check the completeness of the accessories.

19-3-2024