

OPERATING AND INSTALLATION MANUAL

STATIONARY ELECTRIC WATER HEATERS AND HOT WATER STORAGE TANKS

OKCE 750 S

OKCE 1000 S



Družstevní závody Dražice-strojírna s.r.o.
Dražice 69, 294 71 Benátky nad Jizerou
tel.: +420 / 326 370 911
e-mail: export@dzd.cz

 **DRAŽICE**
NIBE GROUP MEMBER

CONTENTS

1	PRODUCT TECHNICAL SPECIFICATION	4
1.1	FUNCTION DESCRIPTION	4
1.2	PRODUCT DESCRIPTION	4
1.3	DESIGN AND GENERAL DIMENSIONS OF WATER HEATERS AND HOT WATER STORAGE TANKS.....	5
1.4	TECHNICAL PARAMETERS	6
2	OPERATION AND FITTING INSTRUCTIONS.....	6
2.1	OPERATING CONDITIONS	6
2.1.1	PLUMBING FIXTURE.....	7
2.2	FURTHER INFORMATION	8
2.3	FIRST COMMISSIONING.....	8
2.4	HEATER CLEANING AND ANODE ROD EXCHANGE.....	9
2.5	SPARE PARTS.....	10
3	IMPORTANT NOTICES	10
3.1	INSTALLATION REGULATIONS.....	10
3.2	TRANSPORT & STORAGE INSTRUCTIONS	11
3.3	DISPOSAL OF PACKAGING MATERIAL AND NON-FUNCTIONING PRODUCT.....	11
4	ASSEMBLY GUIDE FOR ZIP-FASTENER INSULATION	12

CAREFULLY READ THIS MANUAL BEFORE INSTALLING THE WATER HEATER!

Dear Customer,

Družstevní závody Dražice - strojírna s.r.o., would like to thank you for your decision to use a product of our brand. With this guide, we will introduce you to the use, construction, maintenance and other information on electrical water heaters.



The product is not intended to be controlled by

- a) people (including children) with reduced physical, sensual or mental capacities, or
- b) people with insufficient knowledge and experiences unless supervised by responsible person, or unless properly instructed by such responsible person.

The manufacturer reserves the right for engineering modification of the product. The product is designed for permanent contact with drinkable water.

It is recommended to use the product in indoor environment with air temperatures from +2 °C to +45 °C and a relative humidity up to 80 %.

Product's reliability and safety is proven by tests implemented by the Engineering Test Institute in Brno.

Made in the Czech Republic.

Meaning of pictograms used in the Manual



Important information for heater users.



Abiding by the recommendations of the manufacturer serves to ensure trouble-free operation and the long service life of the product.



Caution!
Important notice to be observed.

1 PRODUCT TECHNICAL SPECIFICATION

1.1 FUNCTION DESCRIPTION

OKCE S line water heaters and hot water storage tanks use only electricity for heating. Their nominal performance provides sufficient amount of hot water for flat units, premises, restaurants, and similar establishments.

1.2 PRODUCT DESCRIPTION

OKCE 750 – 1000 S

The storage tank is welded from a steel sheet; it is entirely coated with hot water resistant enamel. For additional corrosion protection a magnesium anode is mounted in the upper part of the tank on the side to adjust the electric potential inside the tank, reducing the risk of corrosion. The vessels have outlets of hot and cold water and a circulation opening welded to them. At the hot water storage tanks on the side under the plastic cover, there is a cleaning and revision opening ended with a flange; various performance heating units with various flanges may be mounted into the opening. Temperature indicator is placed on the hot water storage tank's housing. The heaters include thermal insulation NEODUL LB PP with a thickness 80 mm.

1.3 DESIGN AND GENERAL DIMENSIONS OF WATER HEATERS AND HOT WATER STORAGE TANKS

OKCE 750 S, OKCE 1000 S

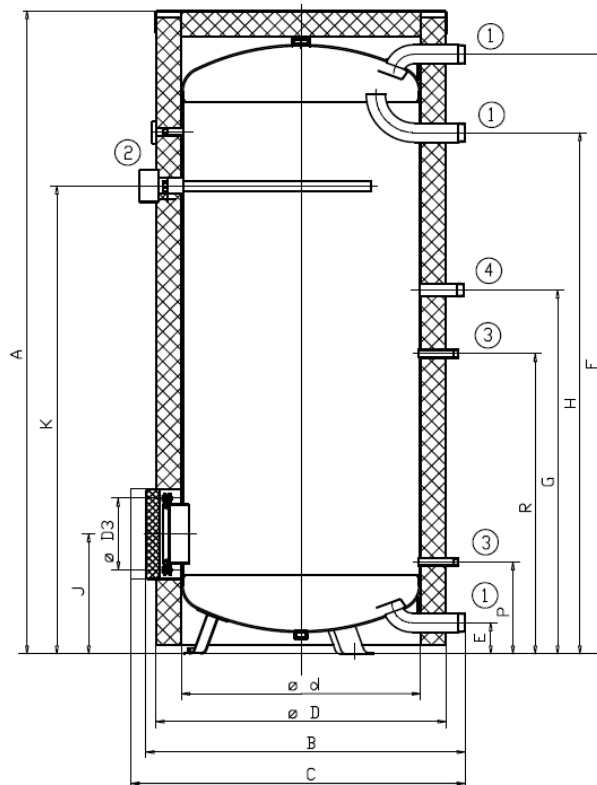

Figure 1

	OKCE 750 S	OKCE 1000 S
A	2030	2050
B	1030	1130
C	max. 1140	max. 1240
d	750	850
D	910	1010
D3	225	225
E	100	100
F	1893	1910
G	1147	1155
H	1642	1650
J	382	390
K	1477	1515
P	292	300
R	947	955

①	2" outer
②	5/4" inner
③	1/2" inner
④	5/4" outer

Table 1

1.4 TECHNICAL PARAMETERS

MODEL	OKCE 750 S	OKCE 1000 S
VOLUME [l]	750	969
WEIGHT [kg]	158	206
MAXIMUM TANK PRESSURE [bar]	10	
MAX WARM WATER TEMPERATURE [°C]	80	
HEATING PERIOD FROM 10°C - 60 °C [h]	Based on selected power input of the built-in unit	
ENERGY EFFICIENCY CLASS	C	C
STATIC LOSS	127	140

Table 2

2 OPERATION AND FITTING INSTRUCTIONS

2.1 OPERATING CONDITIONS



The water heater and hot water storage tank shall only be used in accordance with the conditions specified on the power plate and in instructions for electric wiring. Besides legally acknowledged national regulations and standards, also conditions for connection defined in local electric and water works have to be adhered to, as well as the installation and operation manual.

The temperature at the place of water heater (hot water storage tank) installation must be higher than +2 °C; and the room must not freeze. The appliance has to be mounted at a convenient place; it means that the appliance must be easily available for potential necessary maintenance, repair or replacement, as the case may be.



If water is strongly calcareous we recommend that any of the common decalcifying devices was installed with the appliance, or that the thermostat was set to the maximum operation temperature of 55 °C. For proper operation, drinkable water of adequate quality shall be used. To avoid potential sediments, we recommend that the water heater (hot water storage tank) was installed together with a water filter.

2.1.1 PLUMBING FIXTURE



Power water connects to pipes with 3/4" thread in the bottom part of the water heater (hot water storage tank). Blue – cold water supply, red – hot water outlet. For potential disconnection of the water heater (hot water storage tank), the service water inlets and outlets must be provided with screw coupling Js 3/4". The safety valve is mounted on the cold water inlet identified with a blue ring.



Each water heater (hot water storage tank) must have a safety valve with a membrane spring. Nominal clearance of safety valves is defined by standard. The safety valve must be easily accessible, as close to the water heater (hot water storage tank) as possible. The inlet pipes must have at least the same clearance as the safety valve. Safety valve is placed high enough to secure dripping water drain by gravity. We recommend mounting the safety valve onto a branch pipe. This allows easier exchange without having to drain the water from the heater. Safety valves with fixed pressure settings from the manufacturer are used for the assembly. Starting pressure of a safety valve must be identical to the maximum allowed water heater (hot water storage tank) pressure, and at least 20 % higher than the maximum pressure in the water main (Table 3). If the water main pressure exceeds such value, a reduction valve must be added to the system. **No stop valves can be put between the water heater (hot water storage tank) and the safety valve.** During assembly, follow the guide provided by the safety equipment manufacturer. The cold water inlet of each individually closable water heater (storage tank) must be fitted with a seal, test tap or plug to check the non-return valve, as well as a non-return valve and safety valve. Water heaters and hot water storage tanks with a volume of more than 200 liters must also be fitted with a pressure gauge.



It is necessary to check the safety valve each time before putting it into operation. It is checked by manual moving of the membrane from the seat, turning the make-and-break device button always in the direction of the arrow. After being turned, the button must click back into a notch. Proper function of the make-and-break device results in water draining through the safety valve outlet pipe. In common operation, such a check needs to be implemented at least once a month, and after each water heater (hot water storage tank) shutdown for more than 5 days. Water may be dripping off the drain pipe of the safety valve; the pipe must be open into the air, pointed down; environment temperatures must not drop below zero. When draining the water heater (hot water storage tank), use the recommended drain valve. First, close the water supply into the water heater (hot water storage tank).

Find necessary pressure values in the below - Table 3. For proper safety valve operation, a backflow valve shall be mounted on the inlet pipes, preventing spontaneous water heater (hot water storage tank) draining and hot water penetrating back into the water main. We recommend that the hot water distribution from the water heater (hot water storage tank) was as short as possible to minimize heat losses. At least one demountable joint must be mounted between the water heater (hot water storage tank) and every supply pipe. Adequate piping and fittings with sufficiently dimensioned maximum temperature and pressure values must be used.

Water heaters (hot water storage tanks) must be provided with a discharge valve mounted on the cold service water inlet to the water heater (hot water storage tank) for potential disassembly or repair.

When assembling the security equipment, follow the standard.

SAFETY VALVE START-UP PRESSURE [MPa]	ALLOWABLE OPERATING OVERPRESSURE OF WATER HEATER / STORAGE TANK [MPa]	MAXIMUM PRESSURE IN COLD WATER PIPES [MPa]
0.6	0.6	up to 0.48

Table 3

2.2 FURTHER INFORMATION



750 - 1000 liters capacity water heaters and hot water storage tank are screwed onto the bottom wooden palette with M12 screws. When the water heater (hot water storage tank) is released from the palette and prior to its putting into operation, 3 adjustable legs supplied as the product accessories have to be installed. With these legs, the water heater (hot water storage tank) may be positioned vertically to the base, within 10 mm.

2.3 FIRST COMMISSIONING

After connecting the water heater (hot water storage tank) to the water main, electrical power system, and after checking the safety valve (following the instructions attached to the valve), the water heater (hot water storage tank) can be put into operation. Before opening the power supply, the tank must be filled with water. The process of first heating must be executed by licensed professional who has to check it. Both the hot water outlet pipe and safety armature parts may be hot.

Procedure:

- a) Check the water main and wiring; check proper placement of thermostat sensors. The sensors has to be installed in to the sink as deep as possible - following the possibilities of each capillary, controlling thermostat has to be installed as first sensor in to the capillary, following by the safety thermostat as the second sensor installed in to the capillary;
- b) open the hot water valve on the combination faucet;
- c) open the cold water inlet valve to the water heater (hot water storage tank);
- d) when the water starts flowing through the hot water valve, the filling of the water heater (hot water storage tank) is finished and the valve needs to be closed;
- e) If a flange lid leak is discovered, the flange lid bolts need to be tightened. Screws has to be tightened by cross, tightening moment 15Nm;
- f) fasten the electric installation cover;
- g) when commencing operation, flush the water heater (hot water storage tank) until the cloudiness in the water is gone;
- h) make sure to fill in properly the warranty certificate.

CONNECTING A WATER HEATER AND HOT WATER STORAGE TANK TO HOT WATER SYSTEM

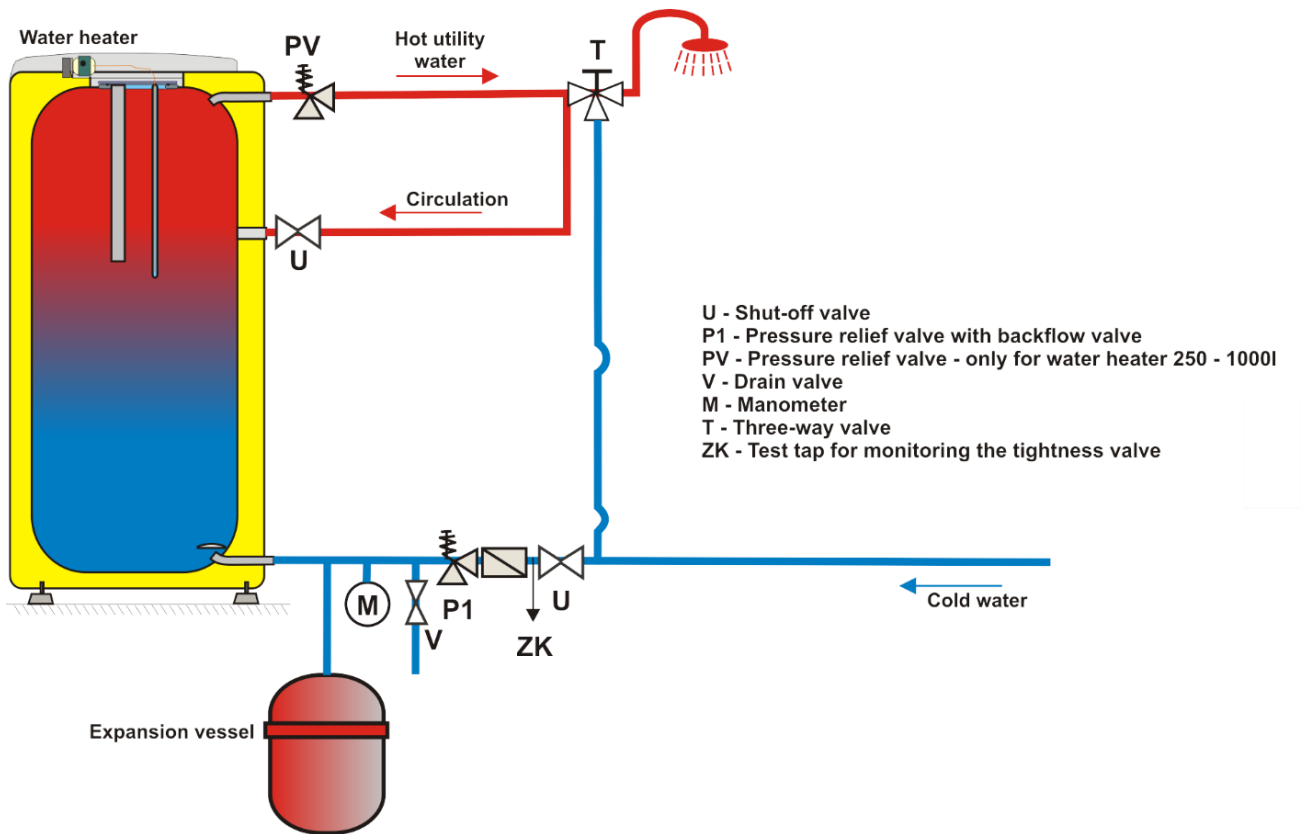

* Use of an expansion vessel is not a condition correct connection only an alternative solution

Figure 2

Water heater (hot water storage tank) with volume exceeding 200 liters at the outlet hot water piping provide combined temperature and pressure safety fittings according to ČSN EN 1490, or the temperature safety fittings fitted with water temperature sensor placed in the heater or other safety valves DN 20, and the opening overpressure compliant with the maximum operating overpressure of the heater vessel. The safety valve does not replace the safety valve on the cold water inlet. No closing, return armature, and filter may be mounted between the water heater (hot water storage tank) and the safety valve.

2.4 HEATER CLEANING AND ANODE ROD EXCHANGE

Repetitive water heating causes limestone sediment on both the enameled tank walls and chiefly the flange lid. Lime scale settling depends on hardness of heated water, its temperature and on the volume of hot water used.



We recommend checking and cleaning the tank from scale and eventual replacement of the anode rod after two years of operation.

The anode life is theoretically calculated for two years of operation; however, it changes with water hardness and chemical composition in the place of use. Based on such an inspection, the next term of anode rod exchange may be determined. Have a company in charge of service affairs deal with the cleaning and exchanging of the anode. When discharging water from the heater, the mixing valve battery for hot water must be open in order to avoid creating under pressure that would prevent water discharge.



To prevent the occurrence of bacteria (e.g. *Legionella pneumophila*) within stack heating it is recommended, if absolutely necessary, to increase the temperature of hot service water (HSW) periodically for a transitional period of time to at least 70 °C. It is also possible to make use of another way of disinfecting HSW.

2.5 SPARE PARTS

- magnesium anode

When ordering spare parts, define the part name, type, and type number from the water heater (hot water storage tank) label.



Do not attempt to repair the failure yourselves. Seek either expert or service help. It does not take much for an expert to remove the defect. When making a repair appointment, report the type and serial number you find on the performance plate of your water heater (hot water storage tank).

3 IMPORTANT NOTICES

3.1 INSTALLATION REGULATIONS



Without a proof issued by a professional company about performed electrical and plumbing fixture the warranty shall be void.

It is necessary to check the protective magnesium anode periodically and replace it if necessary.

No stop valves can be put between the water heater (hot water storage tank) and the safety valve.

If the overpressure in the eater main exceeds 0.48 MPa, a reduction valve must be mounted before the safety valve.

All outlets of hot water must be equipped with combination faucets.

Before the first filling of water heater (hot water storage tank) it is recommended to tighten the nuts of the flange joint of the tank. Screws has to be tightened by cross, tightening moment 15Nm.

It is not allowed to handle the thermostat, aside from temperature resetting with a control button.

All electric installation handling, setting, and regulation feature exchange, may only be implemented by a service company.

If you don't use the water heater (hot water storage tank) for longer than 24 hours, or if the facility with heater is unattended, close the cold water inlet to the heater.

The water heater (hot water storage tank) shall be used exclusively in accordance with the conditions specified on the performance plate and in the instructions for electric wiring.



Both the electric and water installation must follow and meet the requirements and regulations relevant in the country of use!

3.2 TRANSPORT & STORAGE INSTRUCTIONS

The device shall be transported and stored in dry place and protected from weather effects with temperature range from -15 to +50 °C. During loading and unloading the instructions stated on the packaging shall be observed.



Due to the transport and thermal dilating, excessive enamel may fall of the water heaters (hot water storage tank) with exchangers on the tank bottom. This occurrence is common and has no effects on the heater's service life and quality. The decisive enamel layer which remains in the vessel. DZD has many years of experience with this occurrence and it is not a reason for complaints.

3.3 DISPOSAL OF PACKAGING MATERIAL AND NON-FUNCTIONING PRODUCT

A service fee for providing return and recovery of packaging material has been paid for the packaging in which the product was delivered. The service fee was paid pursuant to Act No 477/2001 Coll., as amended, at EKO-KOM a.s. The client number of the company is F06020274. Take the water heater packages to a waste disposal place determined by the town. When the operation terminates, disassemble, and transport the discarded and unserviceable heater to a waste recycling center (collecting yard), or contact the manufacturer.



10-1-2024

4 ASSEMBLY GUIDE FOR ZIP-FASTENER INSULATION

Two people are enough to implement the insulation assembly; three people are required for larger storage tank; the assembly must be implemented in areas with the temperature of at least 18 °C.

If the insulation includes tank bottom insulation, the latter must be mounted first. The insulation is then inserted around the storage tank, respecting the pre-pressed insulation openings. By slight pull in the direction of the arrows, pull both sides of the zip-fastener insulation (Figure 3) so that the insulation does not slide and the insulation holes sit on the storage tank inlets and outlets. It must be secured that, before closing, both halves of the zip-fastener are not further than 20 mm (Figure 4) apart. No foam must get into the zip-fastener on closing.

After the insulation coat is properly mounted and the zip-fastener closed, insert the top lid made of foam material and cover it with either a foil cover or a plastic lid. Alternatively, outlet caps can be glued on the connecting points (Figure 5).

The insulation must be stored in dry areas only.

We take no responsibility for damages caused by not respecting this guide.

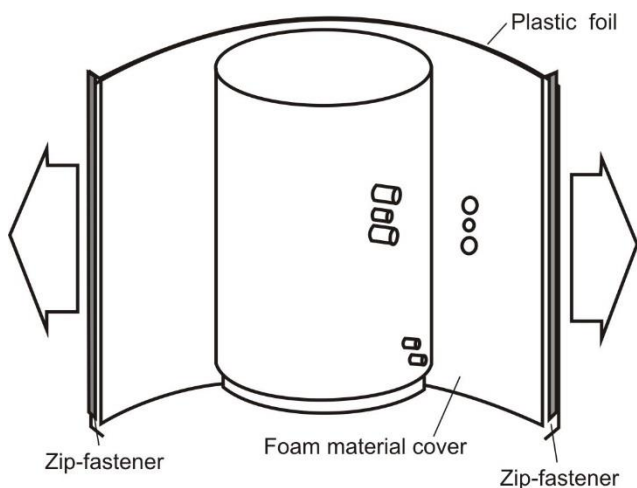

Figure 3

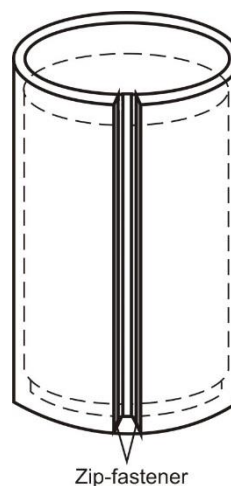

Figure 4

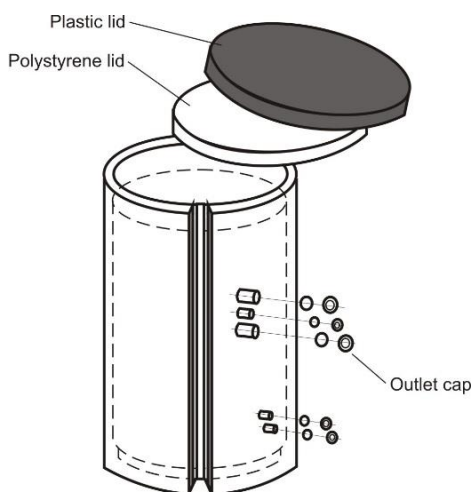

Figure 5