

Limited
EDITION



EXCEPTIONAL AT THE FIRST SIGHT

OKHE ONE/E 80

- › Flat water heater
- › Novelty with electronic thermostat
- › Combines traditional DZD technology
- › Fast water heating thanks to the two-tank concept
- › Possible alternative to gas heater replacement
- › Suitable for installation in confined spaces, can also be installed in a kitchen unit
- › Installation is also possible without a hinge, directly on the wall, or using 4 flexible brackets



 **DRAŽICE**

www.dzd.cz/en

DRAWING WITH DIMENSIONS:

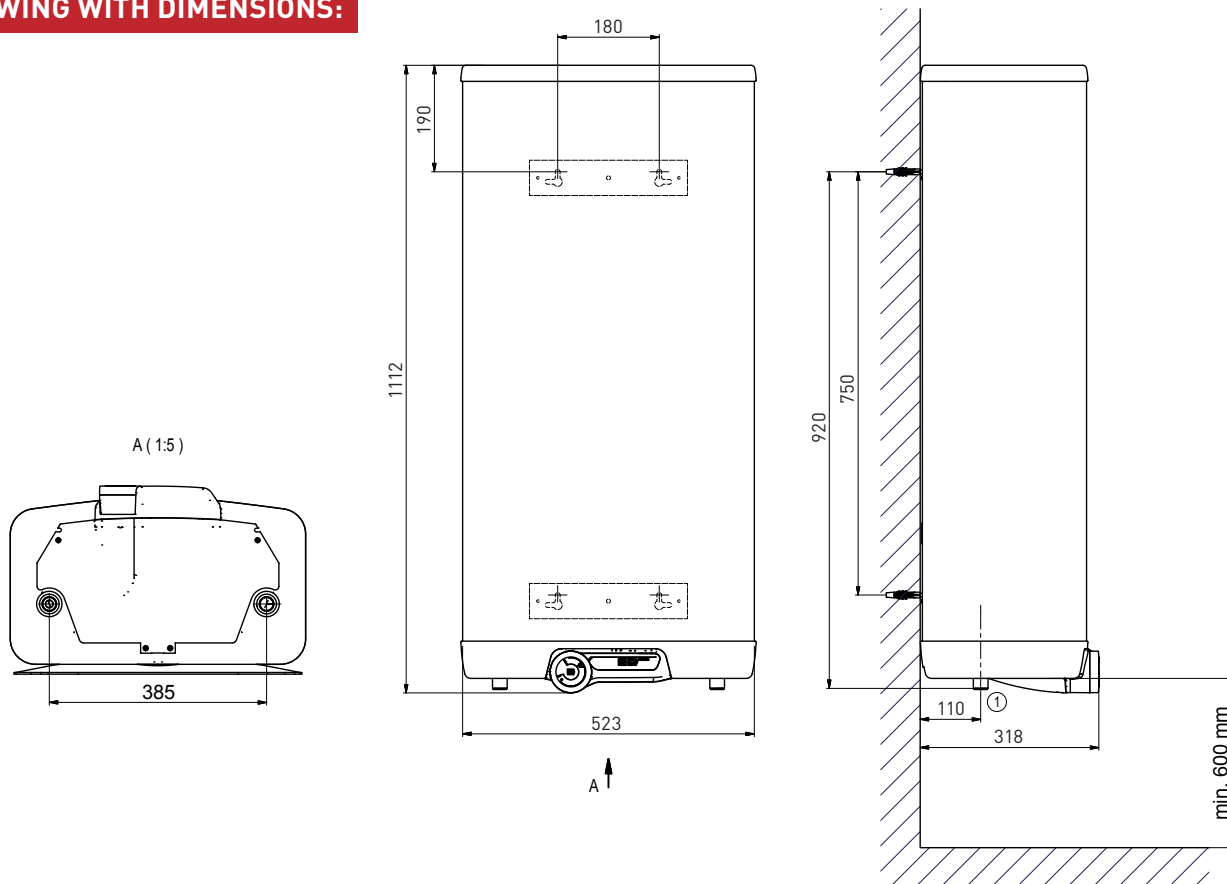

TECHNICAL PARAMETERS:

| Type | OKHE ONE/E 80 |
|--|---------------------|
| Catalogue number | 1801108101 |
| Volume [l] | 65 |
| Dimensions (height × width × depth) [mm] | 1112 × 523 × 318 |
| Maximum weight of water heater (without water) [kg] | 46 |
| Insulation thickness (PUR) [mm] | min. 33 |
| Thermal conductivity of insulation λ [W.m ⁻¹ .K ⁻¹] | 0,022 |
| Heater power consumption [W] | 2 000 |
| Heating time from 10 °C to 60 °C [hours] | 2 |
| Electric connection | 1/N/PE ~230 V/50 Hz |
| Recommended circuit breaker value [A] | 16 |
| Electric protection | IP 44 |
| Maximum operating temperature / overpressure in the vessel [°C/bar] | 80/6 |
| Daily electricity consumption [kWh] | 6,40 |
| Mixed water V40 [l] | 88,77 |
| Load profile | M |
| Energy efficiency class | C |
| Energy efficiency [%] | 37 |
| Annual electricity consumption [kWh] | 1 378 |
| Factory thermostat setting [°C] | 55 |
| Acoustic power [dB] | 15 |
| Function in low electricity tariff only | yes |
| SMART Function | 0 |